



PROJECT: _____
 ITEM # _____ QTY: _____
 MODEL # _____
 AIA # _____ SIS # _____

UNDERCOUNTER FREEZER

UNDERCOUNTER FREEZER

VUF36HC



CABINET CONSTRUCTION

- Stainless Steel Exterior (galvanized back and bottom)
- Aluminum Interior
- Stainless Steel 20 Gauge Door
- One Piece, Snap-In Magnetic Door Gaskets
- 6" Casters Two With Brakes
- 8' Cord And Plug (see electrical data for details)

REFRIGERATION

- Refrigeration System Uses R-290 Refrigerant To Comply With All Environmental Concerns
- Rear Mounted Refrigeration System
- Adaptive Defrost For Reduced Energy Consumption And More Consistent Product Temperatures
- Epoxy Coated Evaporator Coil
- Freezer Capable Of Maintaining Product Temperature -10°F

FEATURES

- Full Electronic Control
- Stay-Open Door Feature For Easy Product Loading
- Heavy-Duty, Spring Loaded Cartridge Hinges
- Low Profile Horizontal Door Handle
- Epoxy Coated Shelves (2 per section)

- ▶ **3 Year Parts & Labor Warranty Plus An Additional 4 Year Compressor Warranty**
- ▶ **Exclusive 2 Year Warranty On Magnetic Door Gaskets**
- ▶ **Lifetime Warranty On Handles & Hinges (Parts Only)**



Please verify qualifying units by visiting:
www.energystar.gov/cfs

OPTIONS & ACCESSORIES

- | | | |
|---|--|---|
| • Stainless Steel Interior | • Cutting Board | • Correctional Package |
| • Stainless Steel Back | • Additional Shelves | • Remote Models* (6" legs only)
(refrigerant must be specified at time of order, see note on back on page) |
| • Secure-Temp™ Technology | • Shelf Clips (set of 4) | |
| • Door Locks | • Casters: 3", Roller Kit, Low Profile | |
| • Door Swing Orientation (at time of order) | • 6" Legs or 6" Seismic Legs | |

3779 Champion Blvd, Winston-Salem, NC 27105

ph: (888) 845-9800 | fax: (800) 253-5168

Sales@VictoryRefrigeration.com | VictoryRefrigeration.com

Rev. 3/17/20 Printed in U.S.A.

APPROVAL: _____ DATE: _____

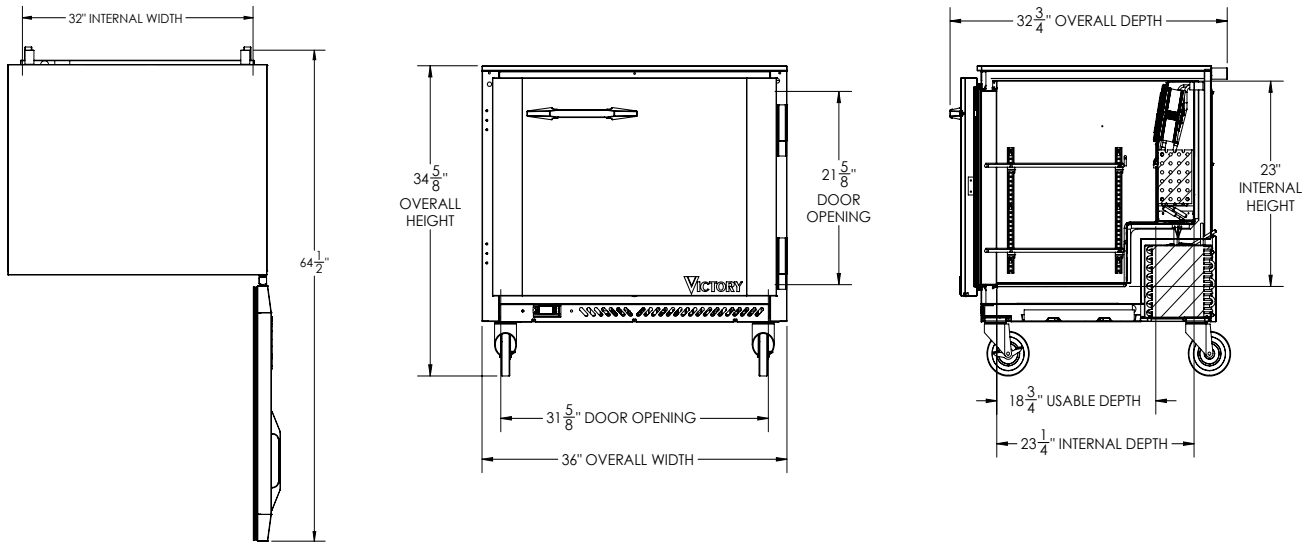

We reserve the right to change specifications and product design without notice. Such revisions do not entitle the buyer to corresponding changes, improvements, additions or replacements for previously purchased equipment. Dimensional tolerances +/- 1/4". Metric dimensions (MM)

CHARACTERISTICS		ELECTRICAL DATA		SHIPPING DETAILS	
Net Capacity	8.69	Cabinet Voltage	115/60/1	Height	38"
Width, Overall (in.)	36"	Total Amperes	6.0	Width	37"
Depth, Overall (with handle)	32 3/4"	NEMA Plug*	5-15P	Depth	33"
Height Overall (6" casters)	34 5/8"	REFRIGERATION DATA		Crated Weight	232 lbs
Depth, Door Open 90°	64 1/2"	Condensing Unit Size, HP*	1/2	*NOTE: Remote units are field wired and comes with 6" legs. Refrigerant must be specified at time of order.	
Door Opening (in.)	31 3/4" x 21 7/8 "	Refrigerant*	R-290		
No. Of Door/Shelves	1/2	Capacity (BTU/HR) (100°F/20°F)	1865		

3779 Champion Blvd, Winston-Salem, NC 27105 | ph: (888) 845-9800 | fax: (800) 253-5168

Sales@VictoryRefrigeration.com | VictoryRefrigeration.com

Rev. 3/17/20 Printed in U.S.A.

an Ali Group Company



The Spirit of Excellence