



BEVERAGE-AIR

Project: _____	AIA#
Item: _____	
Location: _____	SIS#
Approved: _____	

SCHOOL MILK COLD WALL COOLER

SM34HC Single Access Cooler
Hydrocarbon Series

MODELS:
SM34HC-S
SM34HC-W



3 Year Parts/Labor Warranty
Additional 4 Year Compressor Warranty

CABINET CONSTRUCTION

- SS units: Stainless steel exterior and interior
- White units: white coated steel exterior. Interior features a one-piece, stainless steel back, front, and floor. Galvanized side walls for maximum milk crate support
- Stainless steel lids, hinges doors and door latches
- Full electronic control
- Heavy-duty epoxy coated steel wire floor racks standard
- Floor drain is centrally located for easy cleaning and connecting to drain hose with hose adapter
- Flexible compression door gaskets ensure tight seal
- Self-latching doors/lids with safety bumpers
- Exterior thermometer
- Cylinder lock
- 4" Heavy-duty plate casters (2 with locks)
- Maintains product temperature between 36° to 40°F
- Cold wall milk coolers are designed to hold product temperature during service. Product should be removed at the end of service and moved to long-term, refrigerated storage

OPTIONS & ACCESSORIES

- Stainless steel interior on white models -02
- Corner bumpers
- Cafeteria tray slide
- Graphics

REFRIGERATION SYSTEM

- Uses environmentally friendly, energy efficient R290 refrigerant, and meets all regulatory requirements for CARB, SNAP, DOE & more

SM34HC SINGLE ACCESS, COLD WALL: SCHOOL MILK SERIES



Please verify qualifying units by visiting:
www.energystar.gov/cfs

3779 Champion Blvd., Winston-Salem, NC 27105
1-888-845-9800 Fax: 1-336-245-6453
Beverage-Air.com Sales@bevair.com



BEVERAGE-AIR

MODEL	SM34HC (white & stainless steel models)
EXTERNAL DIMENSIONAL DATA	
Width Overall	34"
Depth Overall	30 5/8"
Height Overall with Casters	41 1/8"
Number of Lids/Doors	Single Access
INTERNAL DIMENSIONAL DATA	
NET Capacity (cubic ft.)	12.73
Internal Width Overall (in)	31"
Internal Depth Overall (in)	27"
Internal Height Usable (in)	25 3/4"
CASE CAPACITY	
13" X 13" 11"	8
19" X 13" 11"	4
ELECTRICAL DATA	
Full Load Amperes	2.2
REFRIGERATION DATA	
Horsepower	1/3
Capacity (BTU/Hr)	1224
SHIPPING DATA	
Gross Weight - Crated	277 lbs
Height	48"
Width	33"
Depth	37"

School Milk Cooler Model: SM34HC

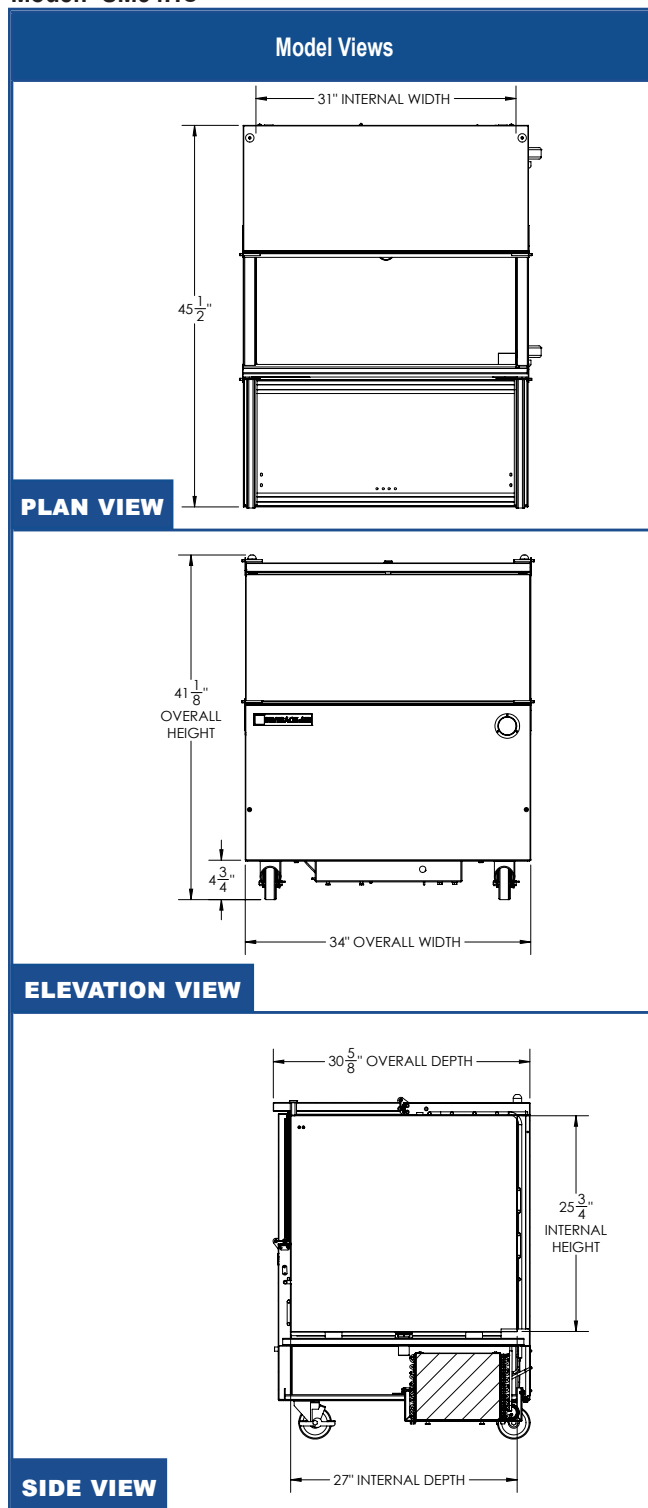

*ELECTRICAL CONNECTION



115/60/1
NEMA 5-15P

Units pre-wired at factory and include 8' long cord and plug set.



3779 Champion Blvd., Winston-Salem, NC 27105 1-888-845-9800 Fax: 1-336-245-6453 Beverage-Air.com Sales@bevair.com

an Ali Group Company



The Spirit of Excellence