



Project: _____	AIA#
Item: _____	
Location: _____	SIS#
Approved: _____	

PH REACH-IN WARMING CABINET

MODEL:
PH2-1HS-PT

PH2 Half-Solid Double Door Pass Thru Warming Cabinet



PH2-1HS-PT

3 Year Parts/Labor Warranty
Additional 4 Year Compressor Warranty

CABINET CONSTRUCTION

- Stainless steel exterior
- Interior liner is made of corrosion resistant aluminum
- Operational indicator panel contains thermometer and adjustable thermostat control which is accurately calibrated from 80°F to 180°F
- Manually controlled humidity vents are provided in the top of the cabinet
- Self closing doors with safety stops
- Heavy-duty cylinder lock and self-adjusting magnetic gasket
- Stainless steel breaker
- Cam-lift hinges
- Three (3) silver freeze shelves
- 6" Adjustable legs standard

OPTIONS & ACCESSORIES

- Pan slides
- 3" or 6" Casters

ELECTRICAL SYSTEM

- 20 AMP breaker required for double door units
- Strip type 750-watt heating elements, operating on 208-240/60/1, having a total of 1500 watts per compartment.
- Externally mounted blower system maintains even temperature through out the food zone area.

PH2 Bottom Mount Models: Warming Cabinet



3779 Champion Blvd., Winston-Salem, NC 27105
1-888-845-9800 Fax: 1-336-245-6453
Beverage-Air.com sales@bevair.com



BEVERAGE-AIR

Warming Cabinet Model: PH2-1HS-PT

MODEL	PH2-1HS-PT
EXTERNAL DIMENSIONAL DATA	
Width Overall	52 1/8"
Depth Overall with Handle	38 3/8"
Height Overall	83 3/4"
Number of Doors	8
Depth with Door Open 90°	84 1/4"
Door Opening (in)	21 1/2" x 25 1/4"
INTERNAL DIMENSIONAL DATA	
NET Capacity (cubic ft.)	43.3
Internal Width Overall (in)	48 1/8"
Internal Depth Overall (in)	26"
Internal Height Overall (in)	56 5/8"
Number of Shelves	6
ELECTRICAL DATA	
Cabinet Voltage 208-240/60/1	208-240/60/1
Max. Fuse Size T.D.	20 AMPS
Feed Wires	2
Heater Watts per section (@240V)	1500
Total Wattage (Heaters & Fan @240V)	3000
Total AMPS	13.00
WEIGHT DATA	
Gross Weight (Crated lbs)	509 lbs
Height - Crated	88"
Width - Crated	60"
Depth - Crated	45"

Model Views

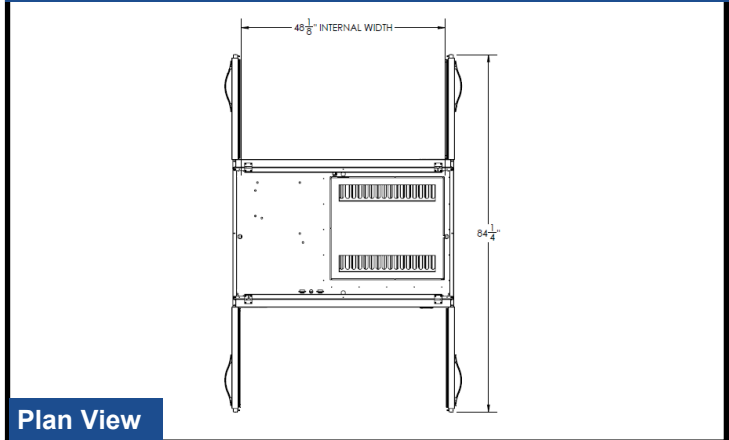

Plan View

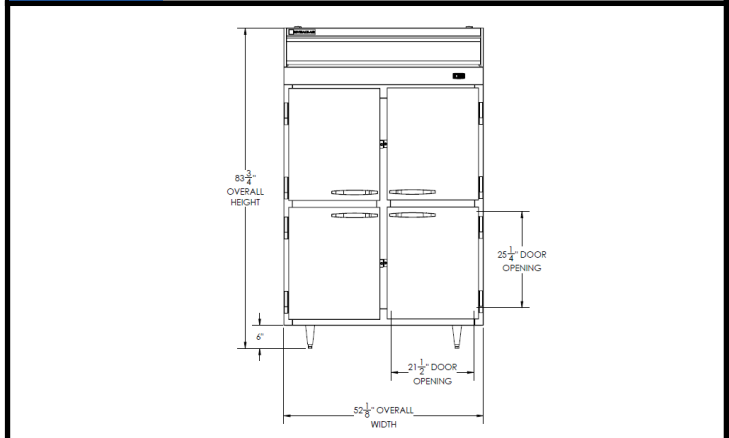

Elevation View

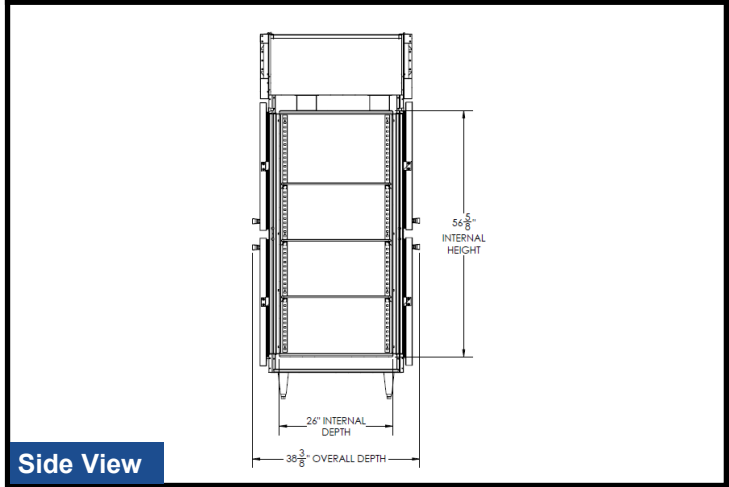

Side View

ELECTRICAL CONNECTION



208-240/60/1
NEMA 6-20A

Units pre-wired at factory and include 8' long cord and plug set.



an Ali Group Company



The Spirit of Excellence

3779 Champion Blvd., Winston-Salem, NC 27105
1-888-845-9800 Fax: 1-336-245-6453
Beverage-Air.com sales@bevair.com