

GRANITE-TOP HEATED DROP-IN MODULE REF: DIC1-4



Rotisol's line of Granite Warmer-Top Drop-Ins provides the most attractive way of displaying and maintaining your hot products for hours. It is ideal for buffet lines, hors d'oeuvres or carving stations.



Thanks to our unique patented system, the heat is uniformly diffused across the entire surface of the granite slab. It is a very even heat, and there is no risk of any cold patches. Our thermostat control allows adjusting the temperature up to 215-220°F.

The drop-in can be installed in any counter. The control panel is connected with a 40" power cord so that it can be placed in the most convenient location. The drop-in is fully insulated and is provided with a factory bracket either located on the top or the bottom for a flush finish! Units come with no groove.

Rotisol granite tops are available in Absolute Black or Sarde White (white with grey and black flecks), whichever best compliments your display area. Other colors and types of stone can be used, but are not supplied by Rotisol.

HEATED DROP-IN DISPLAY MODULES: DIC1-DIC4

STANDARD FEATURES

- All Stainless Steel
- 40" power cord length allows flexibility in placement of controls
- Control panel with regulated temperature digital settings and on/off switch
- Remote control panel
- Granite : black absolute

MODELS	OPTIONS	FINISH
<input checked="" type="checkbox"/> DIC1 : 24" x 20" x 6"	<input checked="" type="checkbox"/> Granite color – Absolute Black or Gray Sarde	<input checked="" type="checkbox"/> Stainless Steel with Granite top
<input checked="" type="checkbox"/> DIC2: 30" x 20" x 6"	<input checked="" type="checkbox"/> Installation configurations: <ul style="list-style-type: none"> • Bottom bracket to allow unit to be flush with the item next to it • Top bracket in SS 	CONNECTION <input checked="" type="checkbox"/> Electrical <input checked="" type="checkbox"/> Single Phase
<input checked="" type="checkbox"/> DIC3 : 30" x 24" x 6"		
<input checked="" type="checkbox"/> DIC4 : 36" x 24" x 6"		



Rotisol-France, Inc Tel/ (800) 651-5969 - (310) 671-7254 Fax/ (310) 671-8171 341 North Oak Street, Los Angeles, CA 90302
 www.rotisolusa.com info@rotisolusa.com

SPECIFICATION GRANITE WARMER DROP IN

TOP BRACKET DETAIL

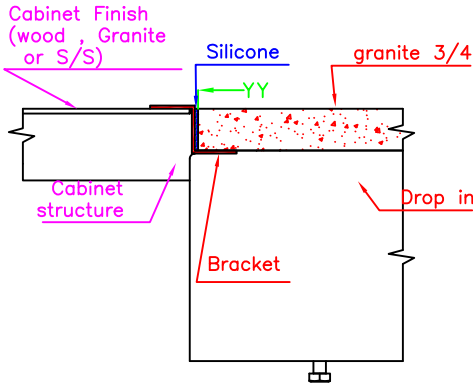

SIDE VIEW

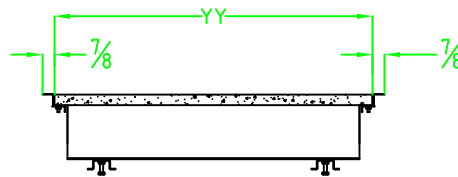

TOP VIEW

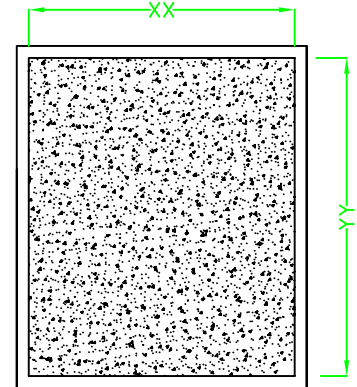

SIDE VIEW

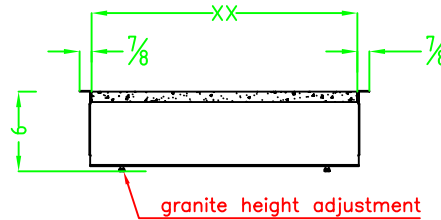

**BOTTOM BRACKET DETAIL
Flush**

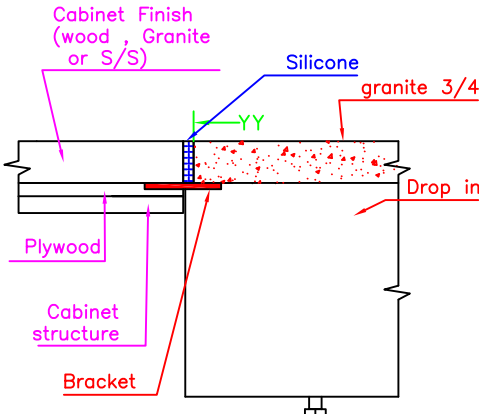

SIDE VIEW

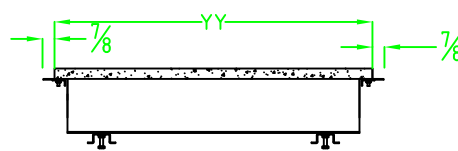

TOP VIEW

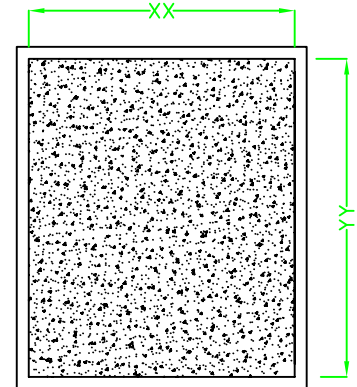

SIDE VIEW

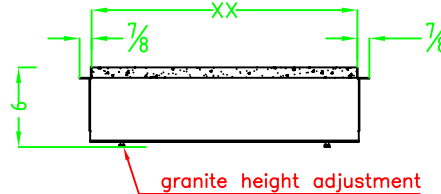

PANEL CONTROL

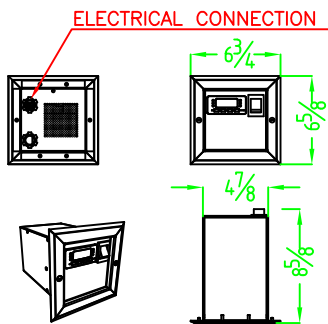

DIMENSION	DIC 1	DIC 2	DIC 3	DIC 4	ELECTRICAL CONNECTION	
SIDE-XX	20	20	24	24	DIC 1	0.8 KW - 208/230 V - 1Ph/G - 4 Amps
SIDE-YY	24	30	36	30	DIC 2	1 KW - 208/230 V - 1Ph/G - 5 Amps
HEIGHT	6	6	6	6	DIC 3	1.6 KW - 208/230 V - 1Ph/G - 8 Amps
DIM. WITH BRACKET					DIC 4	2 KW - 208/230 V - 1Ph/G -10 Amps
WEIGHT						
SIDE	21 3/4	21 3/4	25 3/4	25 3/4	DIC 1	51Lbs - with granite & no packing
SIDE	23 3/4	31 3/4	37 3/4	37 3/4	DIC 2	64 Lbs - with granite & no packing
HEIGHT	6	6	6	6	DIC 3	90 Lbs - with granite & no packing
CUT OUT					DIC 4	110 Lbs - with granite & no packing
SIDE	20 1/2	20 1/2	24 1/2	24 1/2	NOTE	
SIDE	24 1/2	30 1/2	36 1/2	36 1/2		
HEIGHT	N/A	N/A	N/A	N/A	- 1 Electrical cable : 40" length (from panel control)	
Panel control	5	5	5	5	- Nerra plug not provided	
					- electrical cable between drop in and panel control is 40" in length	

WARRANTY CONDITIONS :

Rotisol warrants its equipment to be free from defects in material and workmanship. The warranty covers parts for one year and labor for 6 months. Repairs must be performed by an authorized service company and it is the responsibility of the customer to return the defective parts to Rotisol France, inc. within 15 days(otherwise, the warranty will not be honored). The shipping charges for replacement parts, other than ground, will be at the customer's expense. this warranty does not cover granite top , neither does it cover a mechanical parts. this warranty does not apply to damages by accident, incorrect line voltage, fire, water, or other acts or god.

Technical data

MODULE BUILT STORAGE HOT "Drop'In" SLAB HEATING OF MAINTAINING TEMPERATURE IN GRANITE INTEGRABLE REF.: DIC2

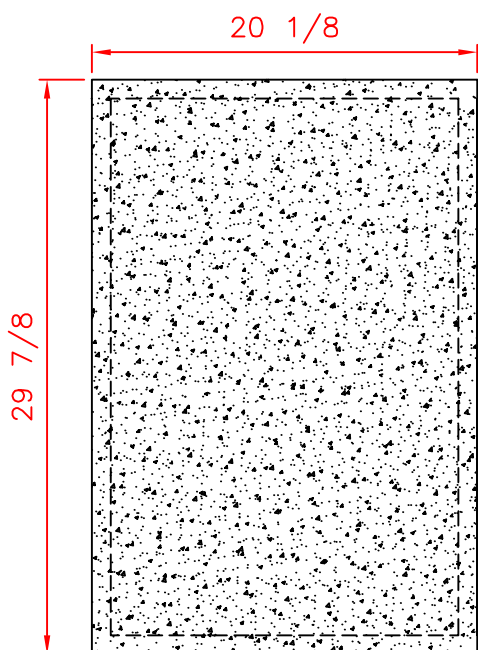
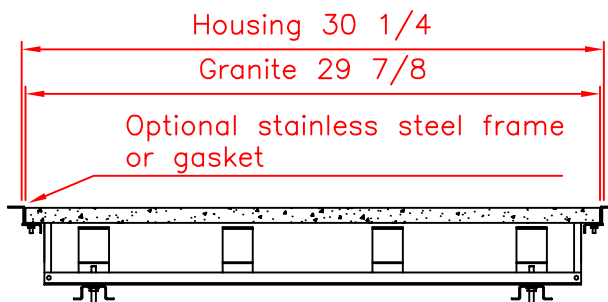
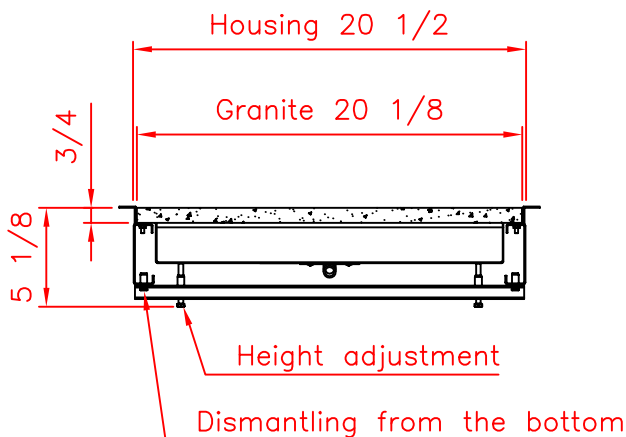

REMOTE CONTROL BOX

Flexible conduit in stainless steel (3 1/4')

Electrical connection 230V~50Hz

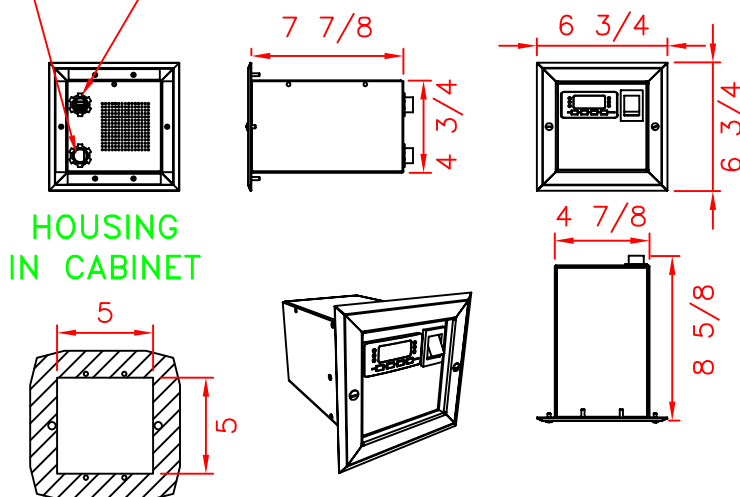

SPECIFICATIONS

Weight: 64 Lbs

Made of stainless steel and aluminium, granite top adjustable in height.

Control panel with a flexible tube distance of 3 1/4' max to be included in cabinet with electronic display and control temperature.

Electrical connection: 230V~50Hz, power cord length 6 1/2'.

Electrical power: 1000 W

OPTIONAL ACCESSORIES: Frame stainless plate granite

All this information are the property of Rotisol. Reproduction partial or in totality are prohibited without authority prior written of company Rotisol