

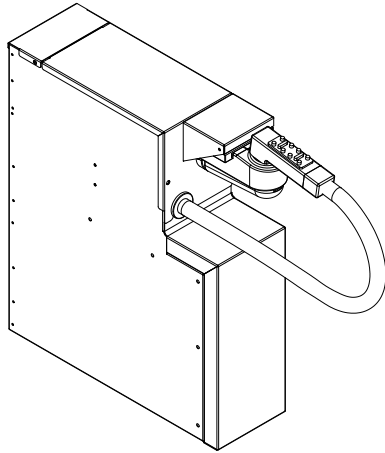

**SODA GUN FILLER SECTIONS**  
**TS AND TSF SERIES**



JOB	
AREA	
ITEM NO.	
MODEL NO.	

<b>TS4SGB</b>	TS Series Model
<b>TS6SGB</b>	TS Series Model
<b>TSF4SGB</b>	TSF Series Model
<b>TSF6SGB</b>	TSF Series Model

Standard 6"  
Backsplash  
Height

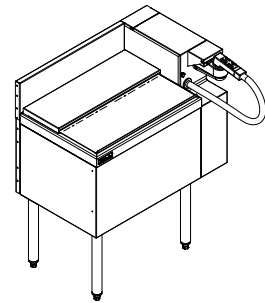

*Shown attached to  
TS24IC10*

**Note:** Soda manifold, hose gun and drip cup NOT included. Shown for clarity of use only.

**Features**

- All stainless steel construction
- Universal design accepts either Wunder-Bar® and Schroeder America™ 8-14 product soda manifolds and drip cups
- Interior mounted manifold conceals unsightly soda lines
- Tool-less removal of Top Cover provides easy service access
- Integrated drip cup mounting allows concealed routing of drip tube to waste drain
- Accessory Speed Rails can by-pass or terminate on Soda Gun Filler
- Speed rails can cross or terminate on soda gun filler.

**Perlick® SODA GUN FILLER SECTIONS**  
**TS AND TSF SERIES**



MODEL NOS.	TS4SGB*	TSF4SGB*	TS6SGB	TSF6SGB
LENGTH IN. (mm)	4" (102)	4" (102)	6" (152)	6" (152)
DEPTH IN. (mm)	18-9/16" (472)	24" (610)	18-9/16" (472)	24" (610)
SHIP WT. LB. (kg)	18 (8.16)	18 (8.16)	18 (8.16)	18 (8.16)
CONSTRUCTION	Stainless Steel			
LEGS	Not applicable, must be mounted to adjacent equipment.			
CAPACITY/APPLICATION	Universal Mounting Brackets accepts "non-flow-control" 8-14 product manifolds from Wunder-Bar® or Schroeder America™ that don't exceed 3" in overall thickness.		Universal Mounting Brackets accepts 8-14 product manifolds from Wunder-Bar® or Schroeder America™	

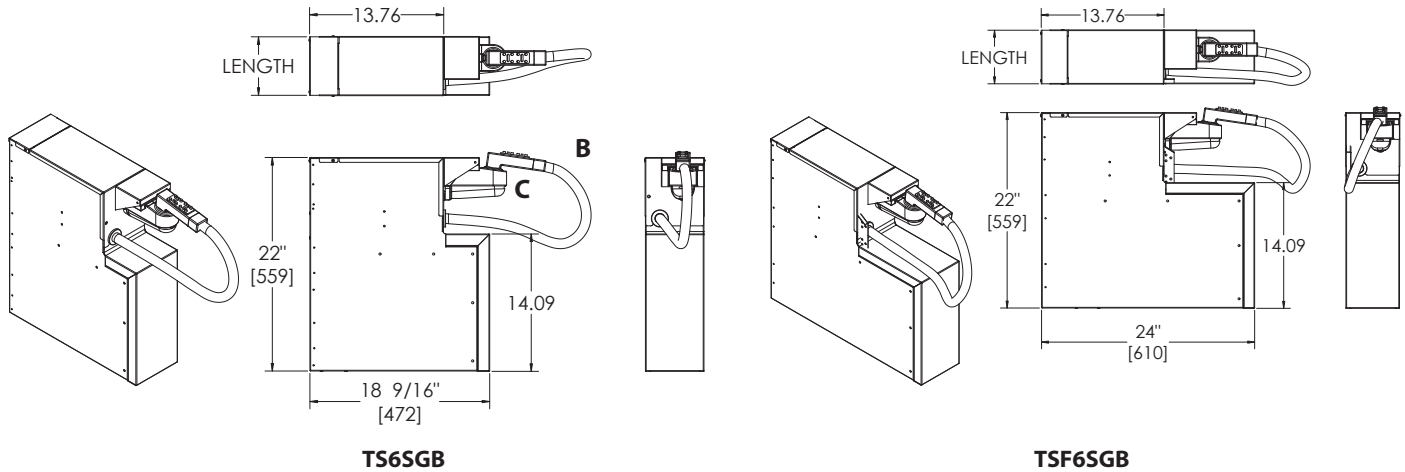

Soda A) manifold; B) hose gun; and C) drip cup  
**NOT included. Shown for clarity only.**

