

Project: _____	AIA# _____
Item #: _____ Qty: _____	SIS# _____
Model #: _____	

## Tubing Chases

TCA, TCB



TCA



TCA shown in an installation setting



### Standard Features

- All stainless steel construction
- Tubing chase is 6" x 6" x 4" high
- Stainless steel drain pan with 1" recess and radius corners for easy cleaning, complete with drain fitting
- Removable stainless steel perforated drain pan insert
- Mounts between adjacent underbar equipment (there is no provision for leg mounting)
- Includes front rail and front skirt to match adjacent equipment
- Can be set in place after beverage lines are installed

### Specifications

#### Drain

- 1-1/2" I.P.S. threaded drain will fit Dearborn part #8033 slip-nut and part #W-573P washer

#### Tubing Chase

- 6" x 6" x 4" high

#### Materials

- 20 gauge stainless steel

#### Mounting

- Must be mounted to adjacent piece of free standing underbar equipment
- No provisions for leg mounting, unit cannot be free standing

To view underbar installation instructions, please visit: [http://www.glastender.com/PDF/F-750-165\\_Underbar\\_Installation\\_Instructions.pdf](http://www.glastender.com/PDF/F-750-165_Underbar_Installation_Instructions.pdf)  
 To view cleaning and care instructions, please visit: [http://www.glastender.com/PDF/F-423-011\\_ss\\_clean\\_care.pdf](http://www.glastender.com/PDF/F-423-011_ss_clean_care.pdf)

### Dimensional Information

TCA

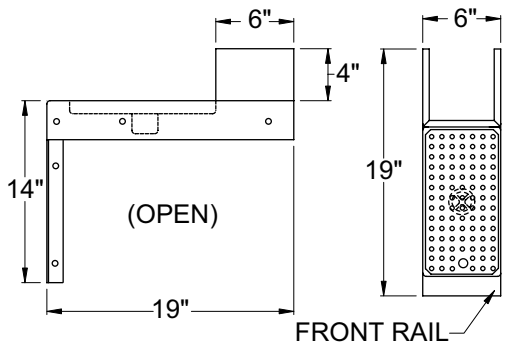

SIDE ELEVATION

PLAN VIEW

TCB

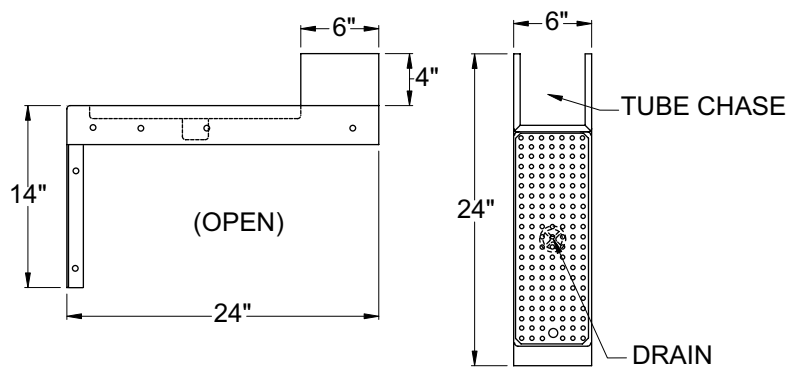

SIDE ELEVATION

PLAN VIEW

<p><b>Glastender, Inc.</b> • 5400 North Michigan Road • Saginaw, MI • 48604-9780                  989.752.4275 • 800.748.0423 • Fax 989.752.4444  <a href="http://www.glastender.com">www.glastender.com</a></p>	<p>Approval/Notes:</p>
<p>Specifications subject to change without notice. For current specifications please visit our website.</p>	