

Project: _____	AIA# _____
Item #: _____ Qty: _____	SIS# _____
Model #: _____	

POS Cabinets

PCB-18, PCB-24



PCB-24



Intertek
 4004503
 Conforms to ANSI/NSF STD 2

Standard Features

- All stainless steel construction with adjustable bullet feet
- One-piece, seamless top and backsplash
- Louvered door features integral handle
- Door lock standard
- Special 26" high work surface height to accommodate cash drawer and POS monitor
- Grommeted cord access hole in work surface
- Large access hole in back wall of unit
- Includes left and right side splashes
- Smooth interior walls for easy cleaning and a finished appearance

Specifications

Legs

- 1-5/8" diameter, 16 gauge stainless steel
- Stainless steel bullet feet

Materials

- 20 gauge stainless steel parts include: all components unless otherwise noted
- 18 gauge stainless steel parts include: leg pads

To view underbar installation instructions, please visit: http://www.glastender.com/PDF/F-750-165_Underbar_Installation_Instructions.pdf
 To view cleaning and care instructions, please visit: http://www.glastender.com/PDF/F-423-011_ss_clean_care.pdf

Dimensional Information

Model Number	X
PCB-18	18"
PCB-24	24"

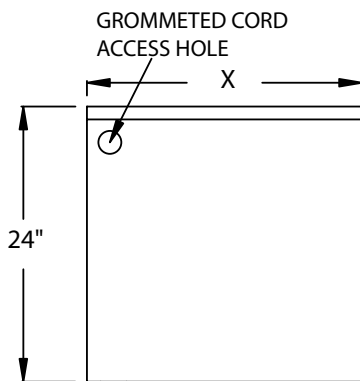

PLAN VIEW

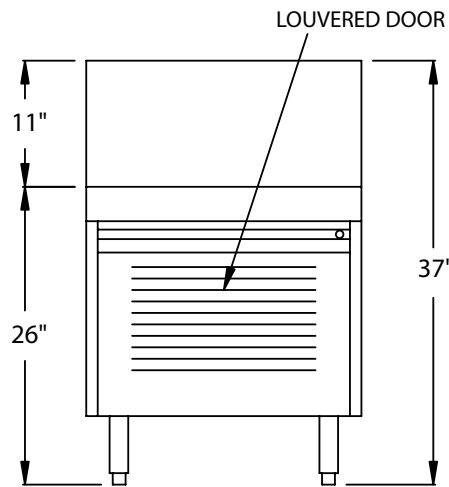

FRONT ELEVATION

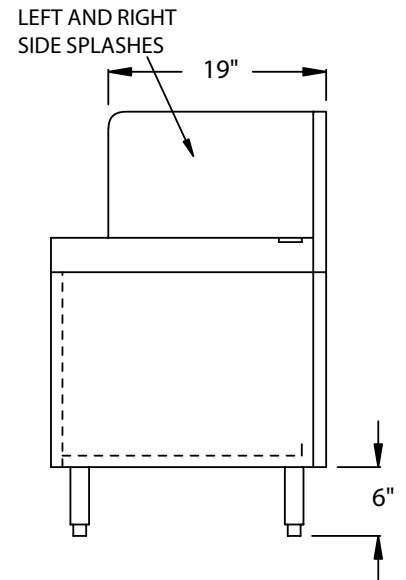

RIGHT SIDE ELEVATION

<p>Glastender, Inc. • 5400 N Michigan Rd • Saginaw, MI • 48604-9780 989.752.4275 • 800.748.0423 • Fax 989.752.4444 www.glastender.com</p>	<p>Approval/Notes:</p>
Specifications subject to change without notice. For current specifications please visit our website.	