

VICTORY[®]

ULTRASPEC

PROJECT: _____

ITEM # _____ QTY: _____

MODEL # _____

AIA # _____ SIS # _____

EXTRA WIDE HALF-DOOR REACH-IN REFRIGERATOR

RS-2D-S1-EW-HD-HC



CABINET CONSTRUCTION

- Stainless Steel Exterior And Interior
- Stay-Open Door Feature For Easy Product Loading
- 20 Gauge Stainless Steel Half-Door
- Magnetic Door Switch Automatically Activates Interior LED Light
- Heavy-Duty Cylinder Locks
- Stainless Steel Interior Door Liner
- One Piece, Snap-In Magnetic Door Gaskets
- Low Profile Vertical Door Handles
- Hinged Front Shroud
- Energy Saving Thermal Breaker
- Stainless Steel Breaker Caps
- Silver Freeze Wire Shelves Per Section
- 6" High Adjustable Stainless Steel Legs
- 8' Cord And Plug (see electrical data for details)

FEATURES

- Full Electronic Control With Touchpoint Interface
- Expansion Valve Technology
- Manager's Lockout Feature
- Anti-Condensate Door Perimeter Heaters
- Variable Speed Compressor Technology

REFRIGERATION

- Refrigeration System Uses R-290 Refrigerant To Comply With All Environmental Concerns
- Hot Gas Condensate Evaporator
- Adaptive Defrost For Reduced Energy Consumption And More Consistent Product Temperatures
- Epoxy Coated Evaporator Coil, Located Out Of The Food Zone
- Refrigerator Capable Of Maintaining Product Temperature 36°F to 38°F



- ▶ 3 Year Parts & Labor Warranty Plus An Additional 4 Year Compressor Warranty
- ▶ Exclusive 2 Year Warranty On Magnetic Door Gaskets
- ▶ Lifetime Warranty On Handles & Hinges (Parts Only)



Please verify qualifying units by visiting:
www.energystar.gov/cfs

OPTIONS & ACCESSORIES

- Secure-Temp™ Technology
- Stainless Steel Case Back
- Stainless Steel Kick Plate
- Exterior Door Laminate
- Glass Half-Door Models
- Door Swing Orientation (at time of order)
- Additional Shelves
- Heat Shield (left, right)
- Tray Slides (type A & A/C)
- 3", 6" Casters Or 6" Seismic Legs
- FlexTemp Models Maintain Between 28°F And 38°F
- Correctional Package
- Remote Models* (6" legs only) (refrigerant must be specified at time of order, see note)

3779 Champion Blvd, Winston-Salem, NC 27105

ph: (888) 845-9800 | fax: (800) 253-5168

Sales@VictoryRefrigeration.com | VictoryRefrigeration.com

Rev. 6/4/20 Printed in U.S.A.

APPROVAL: _____ DATE: _____

EXTRA WIDE HALF-DOOR REACH-IN REFRIGERATOR

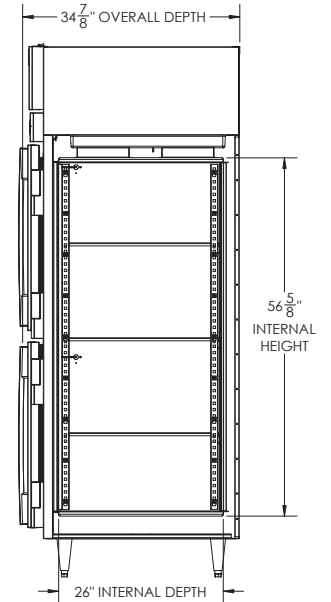
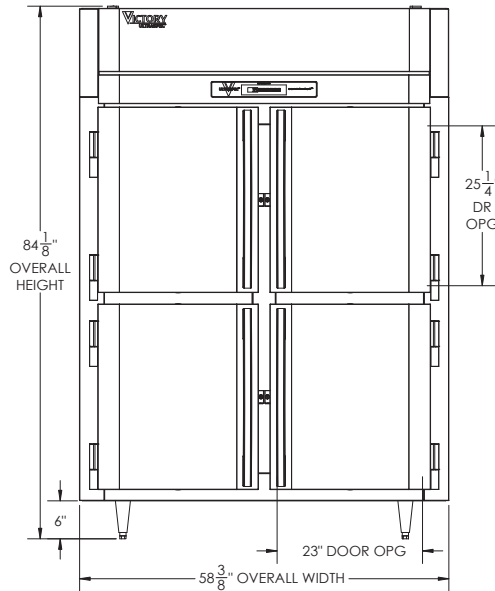
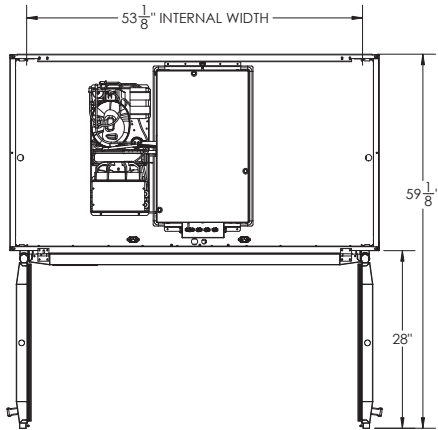

We reserve the right to change specifications and product design without notice. Such revisions do not entitle the buyer to corresponding changes, improvements, additions or replacements for previously purchased equipment. Dimensional tolerances +/- 1/4". Metric dimensions (MM)

12" Top and 3" rear clearance is required

| CHARACTERISTICS | | ELECTRICAL DATA | | SHIPPING DETAILS | |
|-------------------------------|---------------|--------------------------------|---------------------------|---|---------|
| Net Capacity | 49.02 | Cabinet Voltage | 115/60/1 | Height | 88" |
| Width, Overall (in.) | 58 3/8" | Total Amperes | 6.5 | Width | 66" |
| Depth, Overall (with handles) | 34 7/8" | NEMA Plug* (8' cord) | 5-15P | Depth | 41" |
| Height Overall (6" legs) | 84 1/8" | REFRIGERATION DATA | | Crated Weight | 542 lbs |
| Depth, Door Open 90° | 59 1/8" | Condensing Unit Size, HP* | 1/3 | *NOTE: Remote units are field wired and comes with 6" legs. Refrigerant must be specified at time of order. | |
| Door Opening (in.) | 23" x 25 1/4" | Refrigerant* | R-290 | | |
| No. Of Shelves | 6 | Capacity (BTU/HR) (100°F/20°F) | Variable Speed Technology | | |

3779 Champion Blvd, Winston-Salem, NC 27105 | ph: (888) 845-9800 | fax: (800) 253-5168

Sales@VictoryRefrigeration.com | VictoryRefrigeration.com

Rev. 6/4/20 Printed in U.S.A.

an Ali Group Company



The Spirit of Excellence