

VICTORY[®]

ULTRASPEC

PROJECT: _____
 ITEM # _____ QTY: _____
 MODEL # _____
 AIA # _____ SIS # _____

DUAL TEMP SOLID HALF-DOORS REACH-IN REFRIGERATOR/FREEZER

DUAL TEMP SOLID HALF-DOORS REACH-IN REFRIGERATOR/FREEZER

RFSA-2D-S1-HD-HC



CABINET CONSTRUCTION

- Stainless Steel Exterior
- Aluminum Interior
- Refrigerator Is On The Left And Freezer Is On The Right
- Stay-Open Door Feature For Easy Product Loading
- 20 Gauge Stainless Steel Door
- Magnetic Door Switch Automatically Activates Interior LED Light
- Heavy-Duty Cylinder Locks
- Stainless Steel Interior Door Liner
- Insulated Partition Wall Separates Compartments
- One Piece, Snap-In Magnetic Door Gaskets
- Low Profile Vertical Door Handles
- Hinged Front Shroud
- Energy Saving Thermal Breaker
- Stainless Steel Breaker Caps
- Silver Freeze Wire Shelves
- 6" High Adjustable Stainless Steel Legs
- 8' Cord And Plug (see electrical data for details)

FEATURES

- Exclusive Secure-Temp™ Temperature Monitoring Solution
- Full Electronic Control With Touchpoint Interface
- Expansion Valve Technology
- Manager's Lockout Feature
- Anti-Condensate Door Perimeter Heaters
- Variable Speed Compressor Technology

REFRIGERATION

- Refrigeration System Uses R-290 Refrigerant To Comply With All Environmental Concerns
- Hot Gas Condensate Evaporator
- Adaptive Defrost For Reduced Energy Consumption And More Consistent Product Temperatures
- Epoxy Coated Evaporator Coil, Located Out Of The Food Zone
- Refrigerator Capable Of Maintaining Product Temperature 36°F To 38°F
- Freezer Capable Of Maintaining Product Temperature -10°F



- ▶ 3 Year Parts & Labor Warranty Plus An Additional 4 Year Compressor Warranty
- ▶ Exclusive 2 Year Warranty On Magnetic Door Gaskets
- ▶ Lifetime Warranty On Handles & Hinges (Parts Only)



Please verify qualifying units by visiting:
www.energystar.gov/cfs

OPTIONS & ACCESSORIES

- | | | |
|------------------------------|---|--|
| • Stainless Steel Case Back | • Heat Shield (left, right) | • Refrigerator FlexTemp Models Maintain Between 28°F And 38°F |
| • Exterior Door Laminate | • 3", 6" Casters Or 6" Seismic Legs | • Freezer FlexTemp Models Maintain Between 0°F And 20°F |
| • Glass Door Models | • Optional Left Freezer/Right Refrigerator | • Correctional Package |
| • Stainless Steel Kick Plate | • Tray Slides | • Remote Models* (6" legs only) (refrigerant must be specified at time of order, see note) |
| • Additional Shelves | • Door Swing Orientation (at time of order) | |

3779 Champion Blvd, Winston-Salem, NC 27105
 ph: (888) 845-9800 | fax: (800) 253-5168
 Sales@VictoryRefrigeration.com | VictoryRefrigeration.com

Rev. 3/24/20 Printed in U.S.A.

APPROVAL: _____ DATE: _____

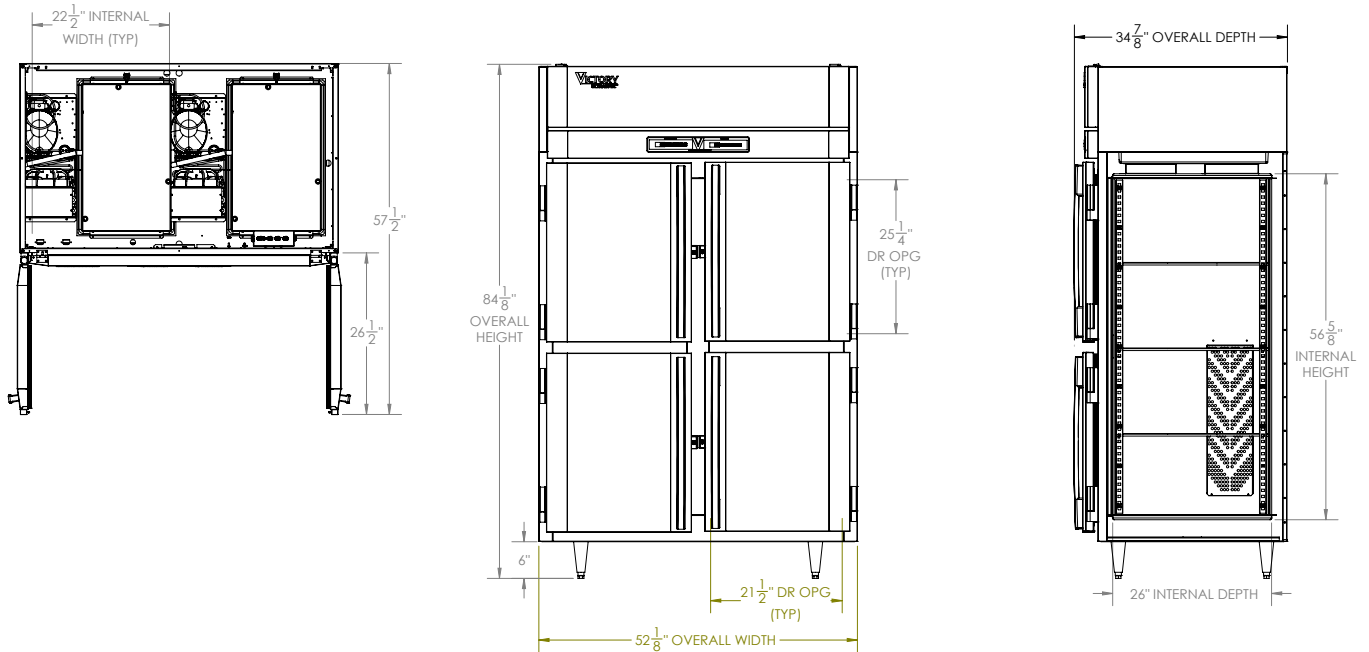

We reserve the right to change specifications and product design without notice. Such revisions do not entitle the buyer to corresponding changes, improvements, additions or replacements for previously purchased equipment. Dimensional tolerances +/- .14". Metric dimensions (MM)

12" Top and 3" rear clearance is required

CHARACTERISTICS		ELECTRICAL DATA		SHIPPING DETAILS	
Net Capacity	R 21.01 - F 21.01	Cabinet Voltage	115/60/1	Height	88"
Width, Overall (in.)	52 1/8"	Total Amperes	R 6.5 - F 9.1	Width	45"
Depth, Overall (with handle)	34 7/8"	NEMA Plug* (8' cord)	(2) 5-15P	Depth	60"
Height Overall (6" legs)	84 1/8"	REFRIGERATION DATA		Crated Weight	680 lbs
Depth, Door Open 90°	57 1/2"	Condensing Unit Size, HP*	R 1/3 - F 3/4	*NOTE: Remote units are field wired and come with 6" legs. Refrigerant must be specified at time of order.	
Door Opening (in.)	21 1/2" x 25 1/4"	Refrigerant*	R-290		
No. Of Doors/Shelves	4/6	Capacity (BTU/HR) (100°F/20°F)	Variable Speed Technology		

3779 Champion Blvd, Winston-Salem, NC 27105 | ph: (888) 845-9800 | fax: (800) 253-5168

Sales@VictoryRefrigeration.com | VictoryRefrigeration.com

Rev. 3/24/20 Printed in U.S.A.

an Ali Group Company



The Spirit of Excellence