

Maestro Plus™

C/E 425 series ice machine for foodservice applications

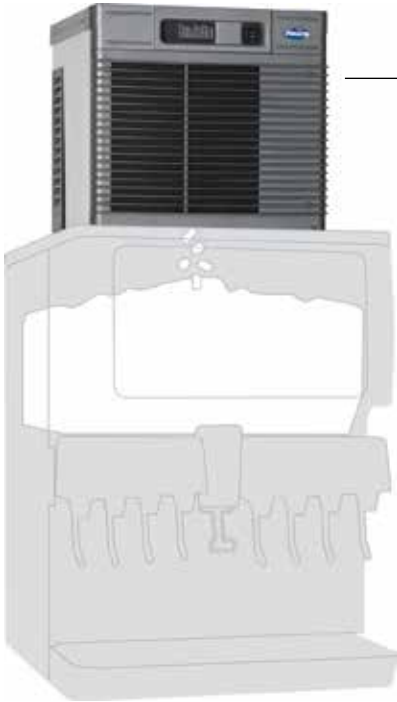

Model MCE425AHT on countertop ice and beverage dispenser, supplied by others



Features

Maestro Plus Chewblet® ice machine with up to 193 kg (425 lb) daily production of Chewblet or flake ice.

High performance Maestro Plus ice machines

- compact, reliable ice machine for top mount installation
- stainless steel evaporator, auger and top bearing
- oversized, heavy duty, tapered roller bearing ensures long low-maintenance life
- automatic self-flushing of ice machine removes impurities
- no noisy harvest cycles means quiet ice production

Lower utility bills

- energy-efficient, no costly defrost cycles
- meets 2018 Department of Energy regulations
- 40% less water than comparable capacity cube machines

Maintenance and service benefits

- cleaning and sanitizing of entire machine takes less than 1 hour
- LED control board provides at-a-glance machine status

Consumer-preferred Chewblet ice (MCC/MCE models)

- chewable, compressed nugget ice is preferred over cubes¹
- available with approximately 2.54 cm (1.00") long standard Chewblet ice or optional 0.95 cm (3/8") long Micro Chewblet™ ice
- more reliable dispensing than nugget or pellet ice
- slow melting, maintains drink temperature and quality, comparable to cubes
- higher displacement than cube ice

Flake ice (MFC/MFE models) is perfect for foodservice and grocery displays

- cradles fish and vegetables without bruising
- securely supports salad bar containers without tipping

Installation flexibility

- Top kits allow ice machine to be top mounted on most ice and beverage dispensers
- Top kits install without any alteration to dispenser (kit includes stainless steel top)
- compatible with over 20 of Follett's ice storage bins

Warranty

- 3 years parts and labor, 5 years compressor parts²

¹ Consumer study conducted by independent agency Roper ASW.

² Refer to price list for additional warranty information.

Model configurations				
Ice type	For use with ¹	Condenser	Voltage V/Hz ²	Item number
Chewblet®	ice storage bin	air	220/60	MCC425ABT
		air	230/50	MCE425ABT
		water	220/60	MCC425WBT
		water	230/50	MCE425WBT
	ice and beverage dispenser (by others)	air	220/60	MCC425AHT
		air	230/50	MCE425AHT
Micro Chewblet	ice storage bin	air	220/60	MMC425ABT
		air	230/50	MME425ABT
		water	220/60	MMC425WBT
		water	230/50	MME425WBT
Flake	ice storage bin	air	220/60	MFC425ABT
		air	230/50	MFE425ABT
		water	220/60	MFC425WBT
		water	230/50	MFE425WBT

¹ Ordered separately.

² Alternate voltage not for use in the United States.

Job

Item

Follett Europe Polska Sp. z o.o.
Mokry Dwór 26C 83-021 Wiślina, Poland
+48 (58) 785-6140 | Fax: +48 (58) 785-6159
folletteurope.com

801 Church Lane | Easton, PA 18040, USA
1.610.252.7301 | Fax: +1.610.250.0696 | follettice.com

FOLLETT®

Accessories

Water filters (refer to form# 9905)

Additional Maestro Plus accessories (refer to price list)

Specification for ice and beverage dispenser top mount ice machines

W1 Width	57.7 cm (22.70") fits on 22.00" wide dispensers
D1 Depth	61.6 cm (24.25")
H1 Height	54.0 cm (21.25")
Service clearance	30.5 cm (12.00") top - no front obstructions 15.24 cm (6.00") on exhaust side (left, right and rear)
C1 220 V/60/1 ("C" models) / 230 V/50/1 ("E" models) electrical	5.5 amps, 0.8 kW 2.4 m (8') cord only
C2 Water inlet	3/8" FPT, installation of an in line water filtration system is recommended
C3 Drain	3/4" MPT water-cooled models require separate condenser drains
Water-cooled ice machine connections	C4 – 3/8" FPT condenser inlet, C5 – 3/8" FPT condenser drain
Refrigerant	R404a for 60 Hz air-cooled models and all water-cooled models R449a for 50 Hz air-cooled models
Air temperature	10 - 38 C (50 - 100 F)
Water temperature	7 - 32 C (45 - 90 F)
Potable water pressure	69 - 483 kPa (10 - 70 psi)
Condenser water pressure	69 - 861 kPa (10 - 125 psi)
Ice production at 21 C (70 F) air, 10 C (50 F) water	60 Hz air-cooled models – 193 kg (425 lb) 50 Hz air-cooled models – 166 kg (365 lb) all water-cooled models – 201 kg (442 lb)
Ice production at 32 C (90 F) air, 21 C (70 F) water	60 Hz air-cooled models – 150 kg (330 lb) 50 Hz air-cooled models – 132 kg (290 lbs) all water-cooled models – 167 kg (368 lb)
Energy consumption 32 C (90 F) air, 21 C (70 F) water	air-cooled models – 5.4 kWh water-cooled models – 5.0 kWh per 45.4 kg (100 lb) ice
Heat rejection	air-cooled models – 5,000 BTU/hr, water-cooled models – 1400 BTU/hr to air, 3600 BTU/hr to water
Water consumption	45.4 L (12.0 gal) of potable water per 45.4 kg (100 lb) of ice (per AHRI test standards). 47.3 L (12.5 gal) at standard flush setting.
Water flow requirement for water-cooled condensers	0.25 gpm at 10 C (50 F) 0.5 gpm at 21 C (70 F) 1.25 gpm at 32 C (90 F)
Approximate ship weight	73 kg (160 lb)
NOTE: For indoor use only	

SHORT FORM SPECIFICATION: Ice machine to be Follett model number _____.
Ice machine to be _____air- or _____water-cooled. Ice machine to produce
chewable nugget ice. Ice machine to have stainless steel evaporator, auger and top
bearings, heavy-duty tapered roller bearing, and low-water safety circuit. 230 V
models CE and EU food contact compliant.

Dimensional drawing

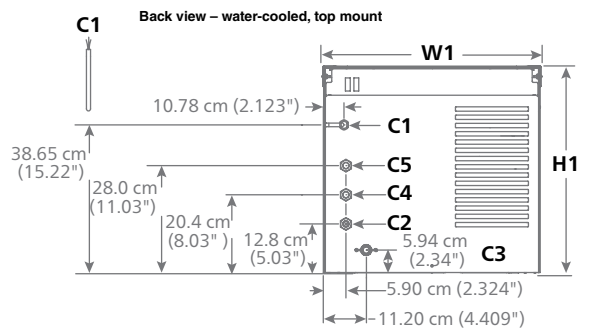
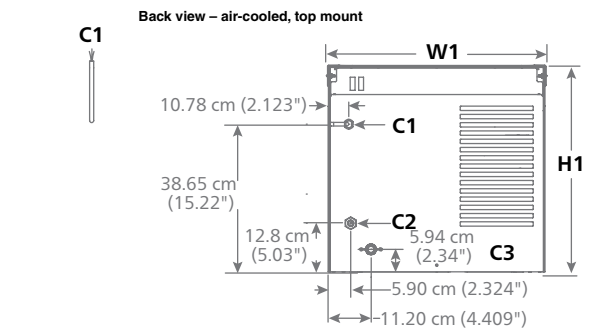
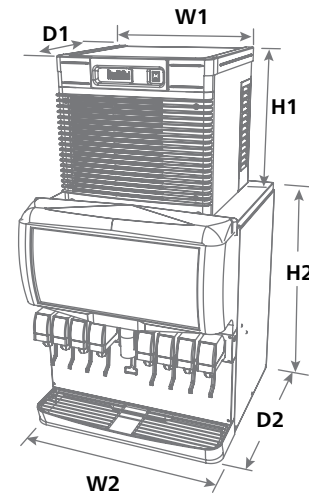

Manufacturer/ Model number	W2 = Width cm (in)	D2 = Depth cm (in)	H2 ¹ = Height cm (in)	Top kit
Coca-Cola dispensers				
Freestyle 7000 ^{2,3}	76.5 (30.10)	84.1 (33.11)	119.4 (47.00)	MTF30SCP
Freestyle 9000 ²	64.8 (25.50)	90.2 (35.50)	187.3 (73.75)	MTF24SCP
Freestyle 9100 ²	64.8 (25.50)	99.7 (39.25)	196.2 (77.25)	MTF26SCP
Cornelius dispensers				
DB/DF/ED150 series	55.9 (22.00)	76.2 (30.0)	87.3 (34.38)	MTC22SCP
DB/DF/ED175 series	62.2 (24.50)	76.2 (30.0)	87.3 (34.38)	MTC24SCP
DB/DF/ED200 series	76.2 (30.00)	76.2 (30.0)	87.3 (34.38)	MTC30SCP
DB/DF/ED250 series	76.2 (30.00)	76.2 (30.0)	97.5 (38.38)	MTC30SCP
Lancer dispensers				
4500-22N, FS-22N	55.9 (22.00)	77.5 (30.50)	92.7 (36.50)	MTL22SCP
4500-30N	76.2 (30.00)	77.5 (30.50)	92.7 (36.50)	MTL30SCP
FS-30N	76.2 (30.00)	77.5 (30.50)	107.0 (42.13)	MTL30SCP
Lancer Sensation	76.2 (30.00)	78.7 (31.00)	97.2 (38.25)	MTL30SCP
Lancer Touchpoint	82.6 (32.50)	85.6 (33.70)	101.6 (40.00)	MTL30SCP
Pepsi dispensers				
Spire 3.0	68.6 (27.00)	88.9 (35.00)	96.8 (38.12)	MTP24SCP
Spire 5.0 / 4.1	77.5 (30.50)	91.4 (36.00)	108.6 (42.75)	MTP30SCP

¹ Net height after installation of top kit.

² Consult with Coca-Cola and Follett to qualify application prior to ordering.

³ Top adapter 46412 and ice kit 46430 must also be ordered from Coca-Cola.

Maestro Plus C/E425 top mount foodservice

Specification for bin top mount ice machines

W1 Width	57.6 cm (22.70") fits on 22.00" wide dispensers or bins
D1 Depth, ice machine	61.6 cm (24.25")
D2 Depth, bin door	80.0 cm (31.50")
H1 Height	54.0 cm (21.25")
Service clearance	30.5 cm (12.00") top - no front obstructions 15.24 cm (6.00") on exhaust side (left, right and rear)
C1 220 V/60/1 ("C" models) / 230 V/50/1 ("E" models) electrical	5.5 amps, 0.8 kW 2.4 m (8') cord only
C2 Water inlet	3/8" FPT, installation of an in line water filtration system is recommended
C3 Drain ¹	3/4" MPT water-cooled models require separate condenser drains
Water-cooled ice machine connections	C4 – 3/8" FPT condenser inlet, C5 – 3/8" FPT condenser drain
Refrigerant	R404a for 60 Hz air-cooled models and all water-cooled models R449a for 50 Hz air-cooled models
Air temperature	10 - 38 C (50 - 100 F)
Water temperature	7 - 32 C (45 - 90 F)
Potable water pressure	69 - 483 kPa (10 - 70 psi)
Condenser water pressure	69 - 861 kPa (10 - 125 psi)
Chewblet ice production at 21 C (70 F) air, 10 C (50 F) water	60 Hz air-cooled models – 193 kg (425 lb) 50 Hz air-cooled models – 166 kg (365 lb) all water-cooled models – 201 kg (442 lb)
Chewblet ice production at 32 C (90 F) air 21 C (70 F) water	60 Hz air-cooled models – 150 kg (330 lb) 50 Hz air-cooled models – 132 kg (290 lbs) all water-cooled models – 167 kg (368 lb)
Flake ice production at 32 C (90 F) air, 21 C (70 F) water	60 Hz air-cooled models – 225 kg (495 lb) 50 Hz air-cooled models – 193 kg (425 lb) all water-cooled models – 234 kg (515 lb)
Chewblet energy consumption 32 C (90 F) air; 21 C (70 F) water	air-cooled models – 5.4 kWh water-cooled models – 5.0 kWh per 45.4 kg (100 lb) ice
Flake energy consumption 32 C (90 F) air; 21 C (70 F) water	water-cooled models – 6.2 kWh per 100 lb (45 kg) ice
Heat rejection	air-cooled models – 5,000 BTU/hr, water-cooled models – 1400 BTU/hr to air, 3600 BTU/hr to water
Water consumption	45.4 L (12.0 gal) of potable water per 45.4 kg (100 lb) of ice (per AHRI test standards). 47.3 L (12.5 gal) at standard flush setting.
Water flow requirement for water-cooled condensers	0.25 gpm at 10 C (50 F) 0.5 gpm at 21 C (70 F) 1.25 gpm at 32 C (90 F)
Approximate ship weight	73 kg (160 lb)

NOTES:

For indoor use only.

Configure with a Follett bin. Refer to the price list, form# 4025.

SHORT FORM SPECIFICATION: Ice machine to be Follett model number _____. Ice machine to be _____air- or _____water-cooled. Ice machine to produce Chewable nugget ice. Ice machine to have stainless steel evaporator, auger and top bearings, heavy-duty tapered roller bearings, and low water safety circuit. NSF listed. 230 V models CE and EU food contact compliant.

Dimensional drawing

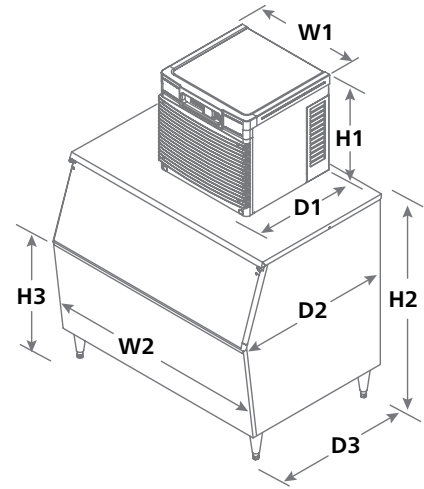

Back view – air-cooled, top mount

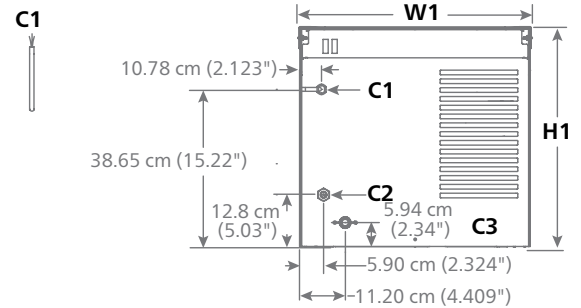

Back view – water-cooled, top mount

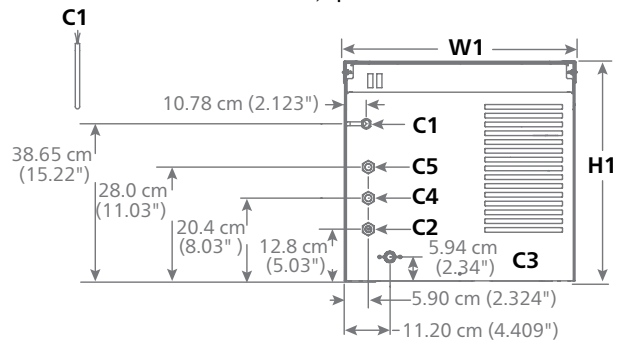

Chewblet ice production – 60 Hz air-cooled models

Inlet water temperature C (F)	Ambient air temperature C (F)					kg (lb) production in 24 hr
	16 (60)	21 (70)	27 (80)	32 (90)	38 (100)	
10 (50)	206 (454)	193 (425)	181 (398)	165 (363)	149 (328)	
16 (60)	198 (437)	185 (408)	172 (379)	157 (346)	143 (314)	
21 (70)	191 (420)	177 (390)	163 (359)	150 (330)	136 (300)	
27 (80)	182 (401)	170 (374)	158 (348)	145 (319)	132 (290)	
32 (90)	173 (381)	163 (359)	153 (337)	140 (308)	127 (280)	

Chewblet ice production – All water-cooled models

Inlet water temperature C (F)	Condenser water temperature C (F)					kg (lb) production in 24 hr
	16 (60)	21 (70)	27 (80)	32 (90)	38 (100)	
10 (50)	206 (454)	201 (442)	196 (431)	190 (419)	185 (408)	
16 (60)	197 (435)	191 (421)	185 (407)	179 (394)	173 (380)	
21 (70)	189 (416)	182 (400)	174 (384)	167 (368)	159 (351)	
27 (80)	180 (396)	173 (381)	166 (365)	159 (350)	152 (335)	
32 (90)	170 (375)	164 (361)	157 (346)	151 (332)	144 (318)	

MAESTRO PLUS and MICRO CHEWBLET are trademarks of Follett LLC.

CHEWBLET and FOLLETT are registered trademarks of Follett LLC, registered in the US.

Follett reserves the right to change specifications at any time without obligation. Certifications may vary depending on country of origin.

Maestro Plus C/E425 top mount foodservice

6955-201911 | © Follett LLC



Follett Europe Polska Sp. z o.o.
 Mokry Dwór 26C 83-021 Wiślina, Poland
 +48 (58) 785-6140 | Fax: +48 (58) 785-6159
 folletteurope.com

801 Church Lane | Easton, PA 18040, USA
 1.610.252.7301 | Fax: +1.610.250.0696 | follettice.com

FOLLETT®