

# TWIN MIXER KETTLE, ELECTRIC LEG MOUNTED, CONSOLE TYPE 2/3 JACKETED, TILTING

Project \_\_\_\_\_  
 Item \_\_\_\_\_  
 Quantity \_\_\_\_\_  
 FCSI Section 11400 \_\_\_\_\_  
 Approved \_\_\_\_\_  
 Date \_\_\_\_\_

## Models

- TMKEL-40-T    • TMKEL-80-T
- TMKEL-60-T    • TMKEL-100-T



Shown with optional Power Tilt & Product Temperature Control

## Standard Features

- Solid State Temperature Control ( $\pm 1^{\circ}\text{F}$ ) for perfect simmering
- Solid State Low Water Safety Control
- Steam Jacket filled with treated water, venting and/or refilling not required
- 50 psi Safety Valve and Steam Jacket Rating
- No Water Gauge required
- Rear mounted Pressure/Vacuum Gauge and Pressure Relief Valve
- Infinitely Variable Scraper Speed Control from 0-40 rpm
- Infinitely Variable Ratio between Scraper And Agitator: Agitator rotates from 0-8 times the speed of the Scraper
- Removable (without tools) Nylon Blades scrape entire Jacketed surface
- 3 Horsepower Hydraulic powered Agitator, Scraper and Bridge Lift
- Safety Device prevents high speed starts
- Mixing stops when bridge is lifted - includes safety cover and screen
- Agitator and Scraper are bayonet mounted for easy removal
- Tilt mechanism of Roller Bearings and case hardened self-Locking worm and segment gear
- Hot and Cold Water Faucets
- 2" diameter Tangent Draw-Off Valve with Drain Strainer
- All Plumbing, Electrical and Hydraulics enclosed in Stainless Steel Consoles
- Enclosed, 10 Gauge Stainless Steel hydraulically operated Mixer Bridge
- Kettle and all Exterior surfaces are Stainless Steel
- Level adjustable feet (flanged for bolting)
- Large Pouring Lip
- Gallon Markings stamped into Scraper Shaft
- Standard 208-240 volts, 60 Hz, 3 phase, 4 wire, high wattage
- Typical approvals include UL., CSA, CE, NSF and ASME

## Short Form Specifications

Shall be CLEVELAND, Model TMKEL- \_\_\_\_\_ -T, console/Leg mounted, Electric Mixer KettleS with permanently filled Steam Jackets; 50 psi Kettle Jacket Ratings and Safety Valves, High Wattage standard, Solid State Temperature ( $\pm 1^{\circ}\text{F}$ ) and Low Water Safety Controls. 3 H.P. Hydraulic powered Scraper/Agitator and Bridge Lift. 0-40 rpm Scraper Speed with Variable Scraper to Agitator Ratio from 1-1 to 8-1. Stainless Steel enclosed Mixer Bridge. All Plumbing, Electrical and Hydraulics enclosed in Consoles. Gallon Markings. Safety Device prevent high speed starts. Safety Device prevents high speed starts; Mixer stops when Bridge is lifted. Bayonet Mounted Agitator and Scraper. 2" Tangent Draw-Off Valve. Hot and Cold Water Faucet. Kettle and all exterior surfaces are Stainless Steel.

## Options & Accessories

- Product Time/Temperature Controls and Indicators
- Food Strainer (FS-20)
- Flow Diverter (FD)
- Pan Carrier (PCK)
- Swing Funnels (SF-1 or SF-2)
- Power Tilt (PT)
- Kettle Accessory Kit (KAK) includes:
  - Clean-up Brush (CB)
  - 36" Kettle Paddle (KP)
  - 36" Kettle Whip (KW)
  - 36" Kettle Brush (KB)
  - Draw-off Brush (DB)
  - 24 oz. Ladle (KL)
- Type 316 Stainless Steel Interior for high acid food products (316-20G)
- Water Meter (GMF or LMF) Wall Mount or on Stand (SWM)
- Leg Extensions (ELTMK)
- Voltages (VOS) other than standard

KE004046-98

**DIMENSIONS ("/mm)**

GAL/LIT	A	C	D	E	F	G	H	J	K	L	M	N	O	P	Q	R	S	T	U	V	W	X	Y	Z	A1	A2
<b>40/150</b>	99.00	26.00	43.25	52.75	72.00	10.25	23.13	10.25	23.13	39.88	27.38	36.00	18.38	28.00	38.00	5.63	27.00	54.38	30.00	44.00	30.50	18.25	76.00	16.00	35.75	39.00
	2511	660	1099	1340	1829	260	587	1416	279	1013	695	915	467	711	965	143	686	1381	762	1118	775	464	1930	406	980	991
<b>60/225</b>	106.00	29.50	43.25	52.75	73.00	10.25	23.13	10.25	23.13	42.13	27.38	36.00	18.38	28.00	41.50	6.50	9.50	58.50	31.00	45.00	34.00	14.75	79.00	18.25	37.50	40.75
	2689	750	1099	1340	1854	260	587	1460	168	1070	695	915	467	711	1054	165	749	1486	787	1143	864	375	2007	464	953	1035
<b>80/300</b>	113.00	33.00	45.75	55.25	79.00	12.75	26.38	10.25	23.13	46.38	32.63	39.25	21.63	31.25	45.00	7.38	31.38	63.00	35.00	46.00	37.50	15.00	84.00	19.13	42.75	46.00
	2867	838	1162	1403	2007	324	670	1500	168	1178	778	997	549	794	1143	187	797	1600	889	1168	953	381	2134	486	1086	1168
<b>100/375</b>	117.88	35.50	47.75	57.25	82.00	14.75	26.38	10.25	23.13	47.63	32.63	39.25	21.63	31.25	47.50	8.00	33.00	66.00	36.00	47.00	40.00	15.00	89.00	20.75	43.75	47.00
	2994	902	1213	1454	2083	375	670	1550	152	1210	778	997	549	794	1207	203	838	1676	914	1194	1016	381	2261	527	1111	1194

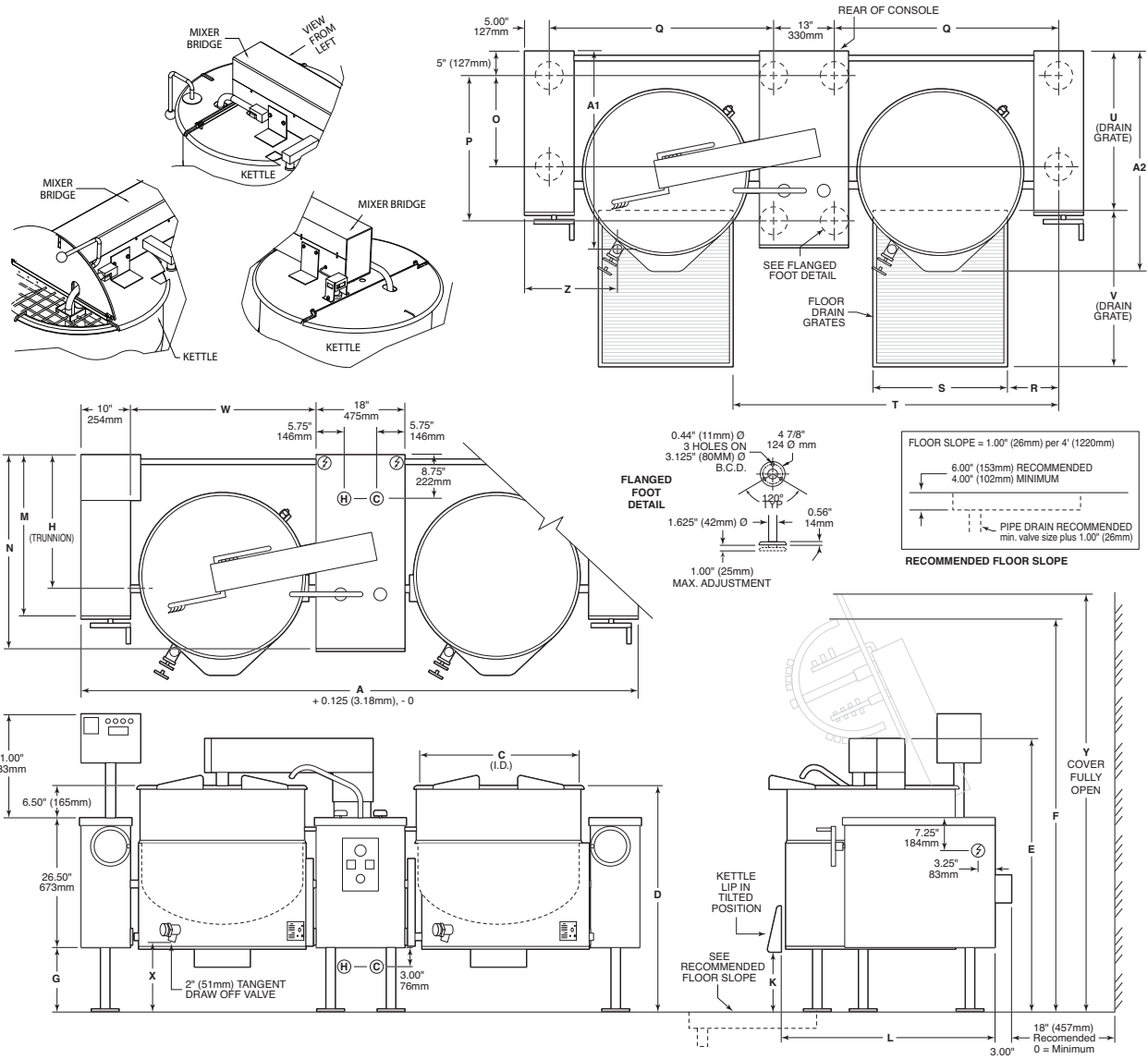

Model	Kettle (Left/Right)				Total Weight	Supply Amps	Wire Size
	Supply Voltage	Phase	Wires	Wt			
TIMKEL-40-T	L 200	3	3	60	22684	81.6	3
	R 200	3	3	60	22684	65.5	4
	L 208	3	3	60	24535	83.8	3
	R 208	3	3	60	24535	68.1	4
	L 220	3	3	60	27448	87.1	2
	R 220	3	3	60	27448	72.0	3
TIMKEL-60-T	L 230	3	3	60	30000	90.0	2
	R 230	3	3	60	30000	75.3	3
	L 240	3	3	60	32665	92.8	2
	R 240	3	3	60	32665	78.6	3
	L 380	3	3	60	25153	47.1	6
	R 380	3	3	60	25153	38.2	6
TIMKEL-80-T	L 400	3	3	60	27871	48.8	6
	R 400	3	3	60	27871	40.2	6
	L 415	3	3	60	30000	50.1	6
	R 415	3	3	60	30000	41.7	6
	L 440	3	3	60	27448	44.1	6
	R 440	3	3	60	27448	36.0	8
TIMKEL-100-T	L 480	3	3	60	32665	46.9	6
	R 480	3	3	60	32665	39.3	6
	L 200	3	3	60	27221	94.7	2
	R 200	3	3	60	27221	78.6	3
	L 208	3	3	60	29442	97.4	1
	R 208	3	3	60	29442	81.7	3
TIMKEL-120-T	L 220	3	3	60	32938	101.5	1
	R 220	3	3	60	32938	86.4	2
	L 230	3	3	60	36000	105.0	1
	R 230	3	3	60	36000	90.4	2
	L 240	3	3	60	39198	108.5	1
	R 240	3	3	60	39198	94.3	2
TIMKEL-160-T	L 380	3	3	60	30184	54.7	6
	R 380	3	3	60	30184	45.9	6

**NOTES:**  
 Cleveland Range reserves right of design improvement or modification, as warranted.  
 Many regional, state and local codes exist and it is the responsibility of the owner and installer to comply with the codes.  
 Installation of backflow preventers, vacuum breakers and other specific code requirements is the responsibility of the owner and installer.  
 Cleveland Range equipment is built to comply with applicable standards for manufacturers. Included among those approval agencies are U.L., A.G.A., NSF, ASME/N.Bd., CSA, CGA, ETL and others.

**Mixer Kettles**

18301 St. Clair Street  
 Cleveland, OH 44110

Tel 1.216.481.4900  
 Fax 1.216.481.3782  
 Email steam@clevelandrange.com

www.clevelandrange.com  
 Section 8, Page 8  
 10 / 2018



(NOT TO SCALE)