



PROJECT: _____
 ITEM # _____ QTY: _____
 MODEL # _____
 AIA # _____ SIS # _____

CHEF BASE FREEZER

CHEF BASE FREEZER

CBF48HC



CABINET CONSTRUCTION

- Stainless Steel Exterior (galvanized back & bottom)
- Aluminum Interior
- Marine Top Standard
- 3" Heavy Duty Casters
- 10' Cord And Plug (see electrical data for details)

REFRIGERATION

- Refrigeration System Uses R-290 Refrigerant To Comply With All Environmental Concerns
- Adaptive Defrost For Reduced Energy Consumption And More Consistent Product Temperatures
- Electric Defrost Heater With Hot Gas Condensate Evaporation
- Freezer Capable Of Maintaining Product Temperature Of -10°F

FEATURES

- High Performance Refrigeration System With Electronic Control
- Top Weight Capacity 1000 lbs
- Heavy-Duty Drawer Slide Roller System
- 275 lbs Drawer Load Rating (per drawer)
- Heavy Duty, Fire-Proof Reinforced Insulated, 16 Gauge Top
- No Heat Shield Required (must adhere to proper clearance per owners manual)
- Accommodates 6" Deep Full Size Food Service Pans (Not Included)
- Self-Closing Drawer Feature
- One Piece, Snap-In, Magnetic Drawer Gasket
- Compressor available on left or right, specify at time of unit order

- ▶ 3 Year Parts & Labor Warranty Plus An Additional 4 Year Compressor Warranty
- ▶ Exclusive 2 Year Warranty On Magnetic Door & Drawer Gaskets
- ▶ Lifetime Warranty On Handles, Drawers & Drawer Slides (Parts Only)



Please verify qualifying units by visiting: www.energystar.gov/cfs

OPTIONS & ACCESSORIES

- Secure-Temp™ Technology
- Drawer Locks
- 6" Legs Or 6" Seismic Legs
- Stainless Steel Back
- Additional Pan Supports
- Flat Top Overhang (any size up to 6" overhang on each side)
- Stainless Steel Interior
- 6" Casters
- Remote Models* (6" legs only) (refrigerant must be specified at time of order, see note on back page)

3779 Champion Blvd, Winston-Salem, NC 27105

ph: (888) 845-9800 | fax: (800) 253-5168

Sales@VictoryRefrigeration.com | VictoryRefrigeration.com

Rev. 7/30/20 Printed in U.S.A.

APPROVAL: _____ DATE: _____

VICTORY CHEF BASE FREEZER

CBF48HC

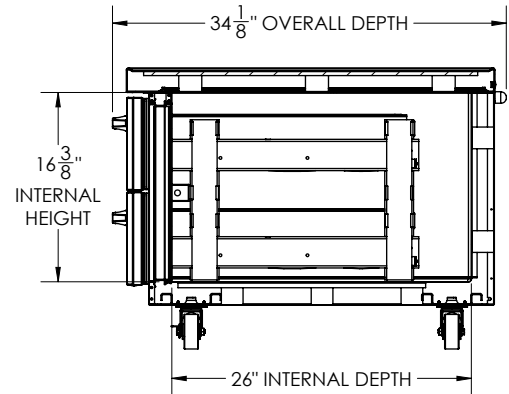
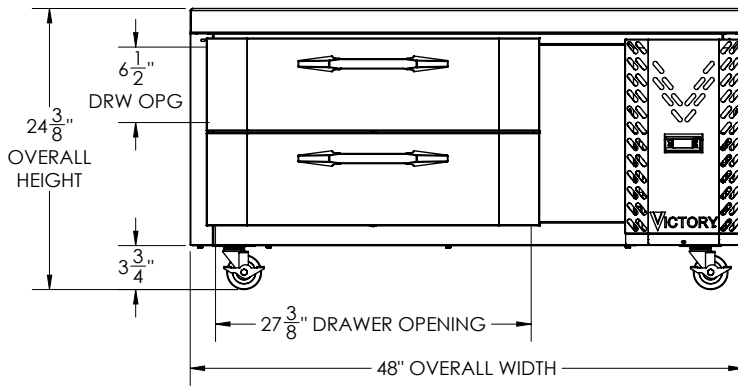
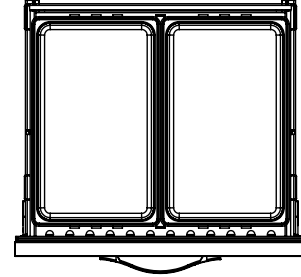
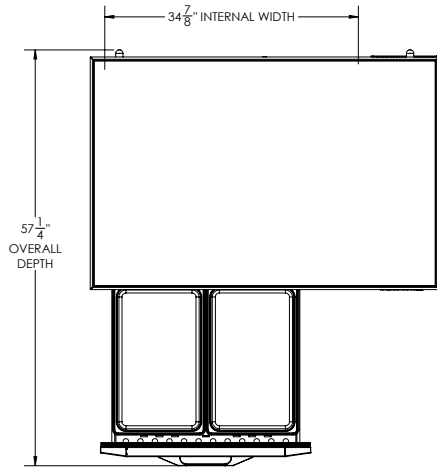

We reserve the right to change specifications and product design without notice. Such revisions do not entitle the buyer to corresponding changes, improvements, additions or replacements for previously purchased equipment. Dimensional tolerances +/- .14". Metric dimensions (MM)

CHARACTERISTICS		ELECTRICAL DATA		SHIPPING DETAILS	
Net Capacity	8.59	Cabinet Voltage	115/60/1	Height	27"
Width, Overall (in.)	48"	Total Amperes	4.50	Width	38"
Depth, Overall (with handle)	34 1/8"	NEMA Plug* (10' Cord)	5-15P	Depth	58"
Height Overall (with casters)	24 3/8"	REFRIGERATION DATA		Crated Weight	375 lbs
Depth, Door Open 90°	57 1/4"	Condensing Unit Size, HP*	1/2	*NOTE: Remote units are field wired and come with 6" legs. Refrigerant must be specified at time of order.	
Drawer Openings (in.)	27 3/8" x 6 1/2"	Refrigerant*	R-290		
No. Of Drawers	2	Capacity (BTU/HR) (100°F/20°F)	1268		

3779 Champion Blvd, Winston-Salem, NC 27105 | ph: (888) 845-9800 | fax: (800) 253-5168

Sales@VictoryRefrigeration.com | VictoryRefrigeration.com

Rev. 7/30/20 Printed in U.S.A.

an Ali Group Company



The Spirit of Excellence