



Project Name: _____

Location: _____

Item #: _____ Qty: _____

Model: _____

INTELLIGENT SERIES SELF-CONTAINED ICE MACHINES

MODEL: MIM320N MIM320NH



Maxx Ice Intelligent Series self-contained, air-cooled ice machines are perfect for any free-standing or built-in application. Available in both full or half dice cubes, each unit features a sanitary self-contained storage bin. The durable stainless steel and black trim exterior is easy to clean and service. The digital controls and front-breathing design with vertical evaporator will deliver years of reliable ice production.

FEATURES AND CONSTRUCTION

- Stainless steel, black trim exterior
- Air-cooled compressor
- Programmable, user-friendly digital controls
- Digital screen displays ice machine status
- Automatic cleaning cycle and bin overflow prevention
- Internal blue LED light
- 6" adjustable leveling legs
- Includes ice scoop with internal scoop holder

DAILY ICE PRODUCTION

Air Temp 70°F (21°C) / Water Temp 50°F (10°C)
MIM320N/NH 328 lbs (148 kg)

Air Temp 90°F (32°C) / Water Temp 70°F (21°C)
MIM320N/NH 244 lbs (111 kg)

ICE BIN STORAGE CAPACITY

MIM320N/H 100 lbs (45 kg)

OPERATING REQUIREMENTS

Ambient Air Temperature Range..... 50° to 100°F (10° to 38°C)

Water Temperature Range 41° to 90°F (5° to 32°C)

Water Usage per 100 lbs of ice..... 13.3 Gallons (50L)

Water Supply Line Connection 3/8" FPT

Water Pressure Range:

Min PSI..... 15 Max PSI 80*

Min Bar 1.0 Max Bar 5.5

*Above 80 PSI requires a regulator

Energy Consumption per 100 lbs of ice:

MIM320N/NH 6.89 kWh/100 lbs

ELECTRIC

115V / 60Hz / 1Ph
(230V / 50-60Hz / 1Ph is available as an option)
6' (2m) NEMA 5-15P cord set included

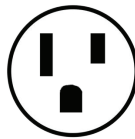

NEMA 5-15P

3RD PARTY APPROVALS



Certified to ANSI NSF 12



Certified to ANSI UL 563



DOE 2018 Compliant



Zero Ozone Depletion Potential

MAXX ICE WARRANTY (USA / CANADA)

Contact Maxx Ice for warranty statement at
TechnicalServices@TheLegacyCompanies.com or 877.368.2797

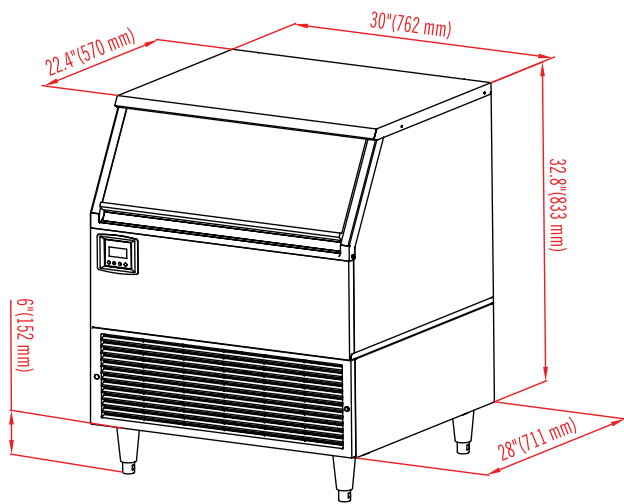

REAR VIEW

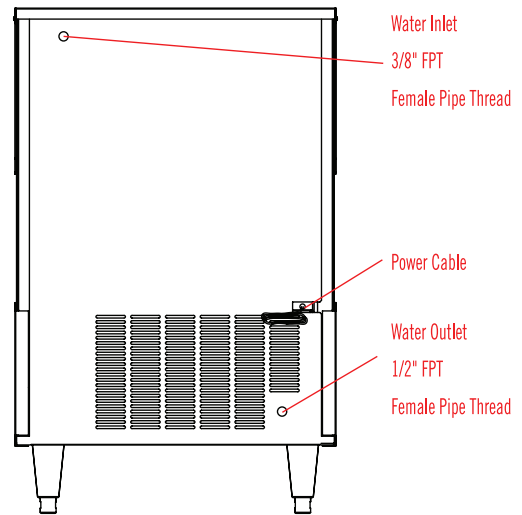

SIDE VIEW

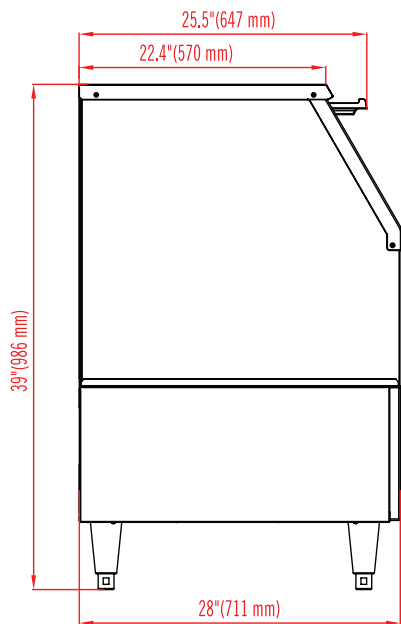

FULL DICE CUBE (N MODELS)

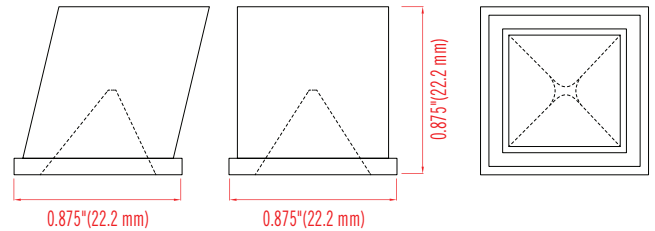

HALF DICE CUBE (NH MODELS)

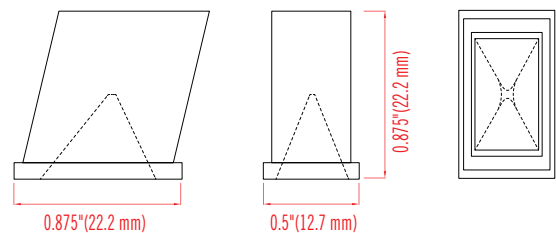

MODEL	EXTERNAL DIMENSIONS	DAILY ICE PRODUCTION (70°F Air / 50°F Water)	ICE BIN STORAGE CAPACITY	NET WEIGHT / SHIPPING WEIGHT	AMP DRAW (MAKING / HARVESTING)	REFRIGERANT AND CHARGE SIZE	ELECTRICAL
MIM320N/NH	30" x 28" x 39" (762 x 711 x 986 mm)	328 lbs (148 kg)	100 lbs (45 kg)	148 lbs (67 kg) 164 lbs (74.4 kg)	8A / 9A	R-404a 12.5 oz (354g)	115V / 60Hz / 1Ph

INSTALLATION

- A clearance of 2" from the wall is recommended to promote adequate cooling air circulation
- A gravity drain line is required to install this ice machine
- For optimal performance, the use of a water filter is recommended