

# 24" DEEP DIRECT DRAW KEG REFRIGERATOR

Project Name: \_\_\_\_\_

Project Location: \_\_\_\_\_

Model #: \_\_\_\_\_ Quantity: \_\_\_\_\_

Available Warehouse: \_\_\_\_\_

## EBD Series Model: EBDS2-24



### Refrigeration System

- Side mounted, self-contained and fully detachable Blizzard R290 condensing unit uses environmentally friendly, EPA-compliant R290 refrigerant with zero (0) Ozone Depletion Potential (ODP) and three (3) Global Warming Potential (GWP). Blizzard R290 is easily replaceable and requires no on-site brazing.
- Electronically commutated (ECM) fan motors achieve rapid cooling with less energy consumption.
- Full-length air duct system ensures optimal circulation of cold air.
- Time-initiated and temperature-terminated auto defrost cycle for seamless operation.
- Large capacity, corrosion-resistant condenser and evaporator coils.
- Self-maintaining, energy-efficient condensate drain pan requires no external drains or electric heaters.
- High performance, auto-reverse condenser fan motor supports compressor ventilation and condenser coil cleaning. Refer to owner's manual for full maintenance instructions.
- Pre-wired and ready to plug, 115V/60Hz/1Ph, NEMA 5-15P.

### Cabinet Construction

- Heavy duty stainless steel countertop with textured laminate, black vinyl exterior.
- Galvanized steel interior walls and high quality stainless steel floor.
- 1 3/4" thick high density polyurethane insulation.
- Built-in caster thread receptacles for all models.

### Lighting

- Energy efficient silicone coated and shatter-proof LED lighting provides bright, high color illumination with low heat output.

### Doors

- Textured laminate, black vinyl exterior with galvanized steel interior.
- 1 3/4" thick high density polyurethane insulation.
- Snap-in magnetic door gasket make cleaning and replacement an easy process.
- High strength, recessed door handles.
- Pre-installed door locks keep your items safe from theft.

### Draft Arms

- Two single faucet, 3" diameter, stainless steel draft arms with matching air distributors. Fully insulated and NSF certified.

### Temperature Control

- Multi-function digital controller with easy to read LED display.
- Factory preset temperature, 35°F.
- Temperature setting range from 33°F to 54°F.
- Audible overheat protection alarm for compressor and condenser coil.

### Options

- Dual or triple faucet draft arms and matching air distributors.
- 3" or 5" swivel casters with locks.
- 3.5" – 6" height-adjustable and interchangeable legs.

 **Operating temperature range is 33°F ~ 54°F**



**5 YEAR Compressor**  
**3 YEAR Parts & Labor**



Please visit our website for updated Energy Efficiency information

Ref/ Frz/Dual	Doors	Capacity		Refrigerant	HP	Power V-Hz-Ph	Amps	Crated Weight	Exterior Dimensions		
		Cu. Ft.	Barrels						L	D	H*
REF	2	13	(1) 1/2 (1) 1/4 Slim	R-290	1/4+	115-60-1	3.5	266 lbs (121kg)	49" (1245mm)	24.5" (622mm)	37.25" (946mm)

(†)Based on evaporating temperature of 23°F (-5°C) & condensing temperature of 131°F (55°C). (P) Product capacity is calculated based on standard industry figures. (x) Reference plan view for clarification on caster/unit height. If dimensions and capacity are critical, please contact Everest Refrigeration. Blizzard R290 replacement is at the sole discretion of Everest Refrigeration. Specifications subject to change without notice.

# 24" DEEP DIRECT DRAW KEG REFRIGERATOR

## EBD Series Model: EBDS2-24

### DIMENSIONAL DATA

External Dimensions	L	49" (1245mm)
	D	24.5" (622mm)
	H*	37.25" (946mm)
Crated Weight	266 lbs. (121kg)	
Doors/Drawers/Lids	2	
Max Weight Support (LBS)	-	

### STORAGE DATA

Net Capacity Cu. Ft. †	13
Shelves	-
Barrels	(1) 1/2 (1) 1/4 Slim
20 oz. Bottles	-
12 oz. Bottles	-
12 oz. Cans	-
8" Mugs	-
# of Pans (Top)	-
# of Pans (Drawer)	-
Dividers	-
Trays	-

### ELECTRICAL DATA

Voltage	115-60-1
Full Load Amperage	3.5
Feed Wires with Ground	3
Cord Length	9ft
NEMA Plug Type	Ⓜ NEMA 5-15P

### REFRIGERATION DATA

Compressor Mounting	Side
Refrigerant	R-290
Compressor HP	1/4+
BTU/HR †	1926

### KEY

<b>R</b>	Refrigerator	<b>D</b>	Door
<b>REF</b>	Refrigerator	<b>L</b>	Lid
<b>F</b>	Freezer	<b>H</b>	Half Door
<b>FRZ</b>	Freezer	<b>FD</b>	Full Door
<b>DUAL</b>	REF/FRZ Combo	<b>SD</b>	Solid Door
<b>DR</b>	Drawer	<b>GD</b>	Glass Door

	Elevation	Right	Plan	3D	Back

### PLAN VIEW

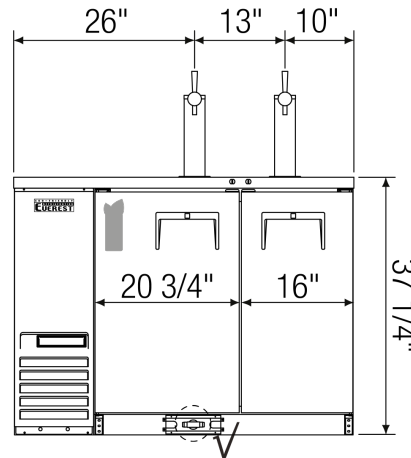

FRONT

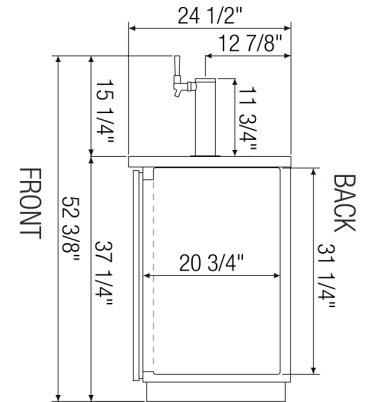

SIDE

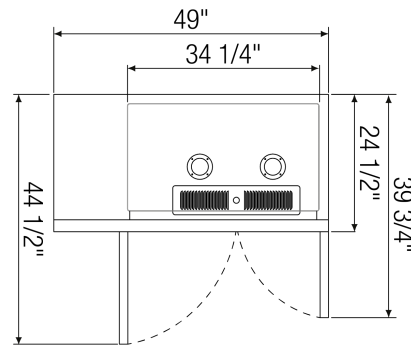

TOP

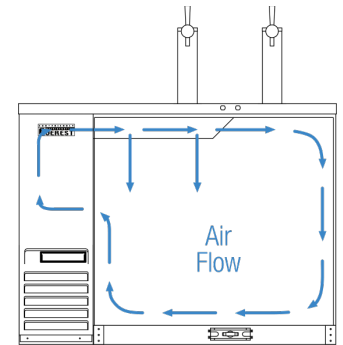

AIRFLOW

### ACCESSORIES & OPTIONS

Part Number	Description
<b>AJL03-00</b>	Interchangeable Leg for Caster
<b>CASA3-01</b>	3" Overall Height Caster Assembly - (2) Front (2) Rear
<b>CASA5-01</b>	5" Overall Height Caster Assembly - (2) Front (2) Rear
<b>OAD01-00</b>	2 Way Air Distributor
<b>OAD02-00</b>	3 Way Air Distributor
<b>ODA01-00</b>	Single Faucet NSF Stainless Steel Draft Arm
<b>ODA02-00</b>	Dual Faucet NSF Stainless Steel Draft Arm
<b>ODA03-00</b>	Triple Faucet 3" NSF Stainless Steel Draft Arm

(†) Based on evaporating temperature of 23°F (-5°C) & condensing temperature of 131°F (55°C). (‡) Product capacity is calculated based on standard industry figures. (✱) Reference plan view for clarification on caster/unit height. If dimensions and capacity are critical, please contact Everest Refrigeration. Blizzard R290 replacement is at the sole discretion of Everest Refrigeration. Specifications subject to change without notice.